SIEMENS

C16x-Family of High-Performance CMOS 16-Bit Microcontrollers

SAB 80C166/83C166

Preliminary SAB 80C166/83C166 16-Bit Microcontroller

- High Performance 16-bit CPU with 4-Stage Pipeline
- 100 ns Instruction Cycle Time at 20 MHz CPU Clock
- 500 ns Multiplication (16×16 bit), 1 μ s Division (32 / 16 bit)
- Enhanced Boolean Bit Manipulation Facilities
- Register-Based Design with Multiple Variable Register Banks
- Single-Cycle Context Switching Support
- Up to 256 KBytes Linear Address Space for Code and Data
- 1 KByte On-Chip RAM
- 32 KBytes On-Chip ROM (SAB 83C166 only)
- Programmable External Bus Characteristics for Different Address Ranges
- 8-Bit or 16-Bit External Data Bus
- Multiplexed or Demultiplexed External Address/Data Buses
- Hold and Hold-Acknowledge Bus Arbitration Support
- 512 Bytes On-Chip Special Function Register Area
- Idle and Power Down Modes
- 8-Channel Interrupt-Driven Single-Cycle Data Transfer Facilities via Peripheral Event Controller (PEC)
- 16-Priority-Level Interrupt System
- 10-Channel 10-bit A/D Converter with 9.7 μ s Conversion Time
- 16-Channel Capture/Compare Unit
- Two Multi-Functional General Purpose Timer Units with 5 Timers
- Two Serial Channels (USARTs)
- Programmable Watchdog Timer
- Up to 76 General Purpose I/O Lines
- Supported by a Wealth of Development Tools like C-Compilers, Macro-Assembler Packages, Emulators, Evaluation Boards, HLL-Debuggers, Simulators, Logic Analyzer Disassemblers, Programming Boards
- On-Chip Bootstrap Loader
- 100-Pin Plastic MQFP Package (EIAJ)

Introduction

The SAB 80C166 is the first representative of the Siemens SAB 80C166 family of full featured single-chip CMOS microcontrollers. It combines high CPU performance (up to 10 million instructions per second) with high peripheral functionality and enhanced IO-capabilities.

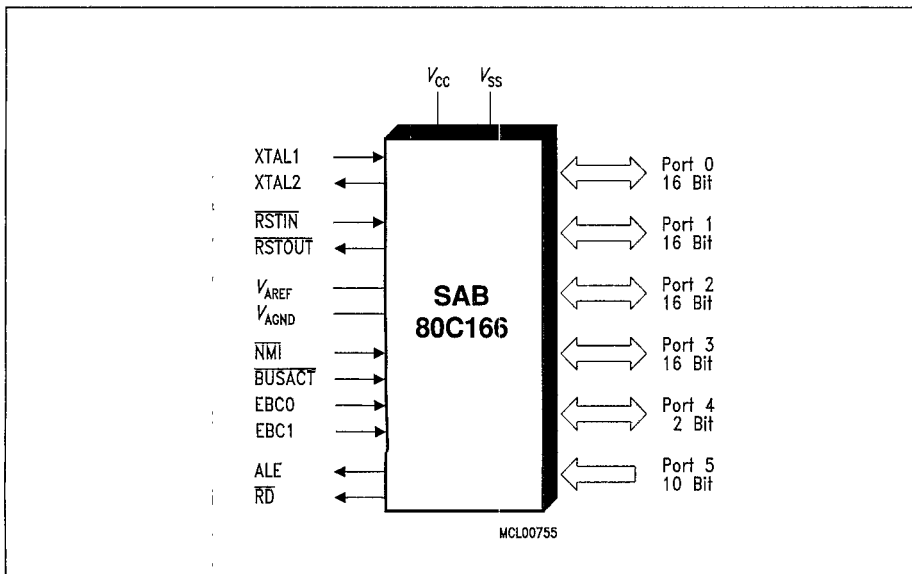

Figure 1
Logic Symbol

Ordering Information

Type	Ordering Code	Package	Function
SAB 83C166-5M	Q67121-D...	P-MQFP-100-2	16-bit microcontroller, 0 °C to +70 °C, 1 KByte RAM and 32 KByte ROM
SAB 83C166-5M-T3	Q67121-D...	P-MQFP-100-2	16-bit microcontroller, -40 °C to +85 °C, 1 KByte RAM and 32 KByte ROM
SAB 80C166-M	Q67121-C848	P-MQFP-100-2	16-bit microcontroller, 0 °C to +70 °C 1 KByte RAM
SAB 80C166-M-T3	Q67121-C900	P-MQFP-100-2	16-bit microcontroller, -40 °C to +85 °C 1 KByte RAM

Note: The ordering codes (Q67120-D...) for the Mask-ROM versions are defined for each product after verification of the respective ROM code.

Pin Configuration Rectangular P-MQFP-100-2
(top view)

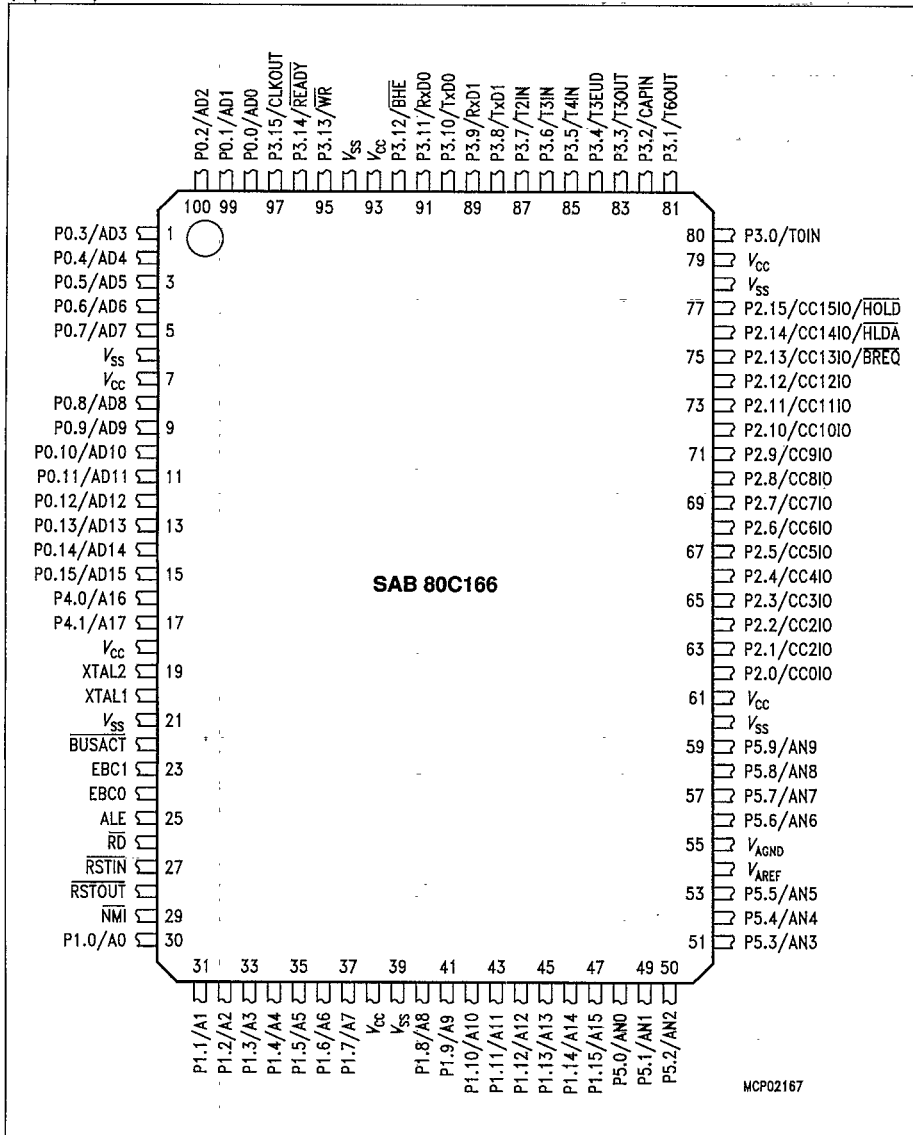

Figure 2

Pin Definitions and Functions

Symbol	Pin Number	Input Output	Function																																				
P4.0 – P4.1	16-17	I/O	Port 4 is a 2-bit bidirectional I/O port. It is bit-wise programmable for input or output via direction bits. For a pin configured as input, the output driver is put into high-impedance state. In case of an external bus configuration, Port 4 can be used to output the segment address lines: P4.0 A16 Least Significant Segment Addr. Line P4.1 A17 Most Significant Segment Addr. Line																																				
XTAL1	20	I	XTAL1: Input to the oscillator amplifier and input to the internal clock generator																																				
XTAL2	19	O	XTAL2: Output of the oscillator amplifier circuit. To clock the device from an external source, drive XTAL1, while leaving XTAL2 unconnected. Minimum and maximum high/low and rise/fall times specified in the AC Characteristics must be observed.																																				
BUSACT, EBC1, EBC0	22, 23, 24	I, I, I	External Bus Configuration selection inputs. These pins are sampled during reset and select either the single chip mode or one of the four external bus configurations: <table border="1"> <thead> <tr> <th>BUSACT</th> <th>EBC1</th> <th>EBC0</th> <th>Mode/Bus Configuration</th> </tr> </thead> <tbody> <tr> <td>0</td> <td>0</td> <td>0</td> <td>8-bit demultiplexed bus</td> </tr> <tr> <td>0</td> <td>0</td> <td>1</td> <td>8-bit multiplexed bus</td> </tr> <tr> <td>0</td> <td>1</td> <td>0</td> <td>16-bit multiplexed bus</td> </tr> <tr> <td>0</td> <td>1</td> <td>1</td> <td>16-bit demultiplexed bus</td> </tr> <tr> <td>1</td> <td>0</td> <td>0</td> <td>Single chip mode</td> </tr> <tr> <td>1</td> <td>0</td> <td>1</td> <td>Reserved.</td> </tr> <tr> <td>1</td> <td>1</td> <td>0</td> <td>Reserved.</td> </tr> <tr> <td>1</td> <td>1</td> <td>1</td> <td>Reserved.</td> </tr> </tbody> </table> ROMless versions must have pin BUSACT tied to '0'.	BUSACT	EBC1	EBC0	Mode/Bus Configuration	0	0	0	8-bit demultiplexed bus	0	0	1	8-bit multiplexed bus	0	1	0	16-bit multiplexed bus	0	1	1	16-bit demultiplexed bus	1	0	0	Single chip mode	1	0	1	Reserved.	1	1	0	Reserved.	1	1	1	Reserved.
BUSACT	EBC1	EBC0	Mode/Bus Configuration																																				
0	0	0	8-bit demultiplexed bus																																				
0	0	1	8-bit multiplexed bus																																				
0	1	0	16-bit multiplexed bus																																				
0	1	1	16-bit demultiplexed bus																																				
1	0	0	Single chip mode																																				
1	0	1	Reserved.																																				
1	1	0	Reserved.																																				
1	1	1	Reserved.																																				
RSTIN	27	I	Reset Input with Schmitt-Trigger characteristics. A low level at this pin for a specified duration while the oscillator is running resets the SAB 80C166. An internal pullup resistor permits power-on reset using only a capacitor connected to V_{SS} .																																				
RSTOUT	28	O	Internal Reset Indication Output. This pin is set to a low level when the part is executing either a hardware-, a software- or a watchdog timer reset. RSTOUT remains low until the EINIT (end of initialization) instruction is executed.																																				

Pin Definitions and Functions (cont'd)

Symbol	Pin Number	Input Output	Function
$\overline{\text{NMI}}$	29	I	Non-Maskable Interrupt Input. A high to low transition at this pin causes the CPU to vector to the NMI trap routine. When the PWRDN (power down) instruction is executed, pin $\overline{\text{NMI}}$ must be low in order to force the SAB 80C166 to go into power down mode. If $\overline{\text{NMI}}$ is high, when PWRDN is executed, the part will continue to run in normal mode. If not used, pull $\overline{\text{NMI}}$ high externally.
ALE	25	O	Address Latch Enable Output. Can be used for latching the address into external memory or an address latch in the multiplexed bus modes.
$\overline{\text{RD}}$	26	O	External Memory Read Strobe. $\overline{\text{RD}}$ is activated for every external instruction or data read access.
P1.0 – P1.15	30-37 40-47	I/O	Port 1 is a 16-bit bidirectional I/O port. It is bit-wise programmable for input or output via direction bits. For a pin configured as input, the output driver is put into high-impedance state. Port 1 is used as the 16-bit address bus (A) in demultiplexed bus modes and also after switching from a demultiplexed bus mode to a multiplexed bus mode.
P5.0 – P5.9	48-53 56-59	I I	Port 5 is a 10-bit input-only port with Schmitt-Trigger characteristics. The pins of Port 5 also serve as the (up to 10) analog input channels for the A/D converter, where P5.x equals ANx (Analog input channel x).
P2.0 – P2.15	62-77	I/O	Port 2 is a 16-bit bidirectional I/O port. It is bit-wise programmable for input or output via direction bits. For a pin configured as input, the output driver is put into high-impedance state. The following Port 2 pins also serve for alternate functions: P2.0 CC0IO CAPCOM: CC0 Cap.-In/Comp.Out P2.13 CC13IO CAPCOM: CC13 Cap.-In/Comp.Out, $\overline{\text{BREQ}}$ External Bus Request Output P2.14 CC14IO CAPCOM: CC14 Cap.-In/Comp.Out, $\overline{\text{HLDA}}$ External Bus Hold Acknowl. Output P2.15 CC15IO CAPCOM: CC15 Cap.-In/Comp.Out, $\overline{\text{HOLD}}$ External Bus Hold Request Input
	62	I/O	
	75	I/O	
	76	I/O	
	77	O	
		I/O	
		I	

Pin Definitions and Functions (cont'd)

Symbol	Pin Number	Input Output	Function																		
P3.0 – P3.15	80-92, 95-97	I/O	<p>Port 3 is a 16-bit bidirectional I/O port. It is bit-wise programmable for input or output via direction bits. For a pin configured as input, the output driver is put into high-impedance state.</p> <p>The following Port 3 pins also serve for alternate functions:</p> <p>P3.0 T0IN CAPCOM Timer T0 Count Input</p> <p>P3.1 T6OUT GPT2 Timer T6 Toggle Latch Output</p> <p>P3.2 CAPIN GPT2 Register CAPREL Capture Input</p> <p>P3.3 T3OUT GPT1 Timer T3 Toggle Latch Output</p> <p>P3.4 T3EUD GPT1 Timer T3 Ext.Up/Down Ctrl.Input</p> <p>P3.5 T4IN GPT1 Timer T4 Input for Count/Gate/Reload/Capture</p> <p>P3.6 T3IN GPT1 Timer T3 Count/Gate Input</p> <p>P3.7 T2IN GPT1 Timer T2 Input for Count/Gate/Reload/Capture</p> <p>P3.8 TxD1 ASC1 Clock/Data Output (Asyn./Syn.)</p> <p>P3.9 RxD1 ASC1 Data Input (Asyn.) or I/O (Syn.)</p> <p>P3.10 TxD0 ASC0 Clock/Data Output (Asyn./Syn.)</p> <p>P3.11 RxD0 ASC0 Data Input (Asyn.) or I/O (Syn.)</p> <p>P3.12 \overline{BHE} Ext. Memory High Byte Enable Signal</p> <p>P3.13 \overline{WR} External Memory Write Strobe</p> <p>P3.14 READY Ready Signal Input</p> <p>P3.15 CLKOUT System Clock Output (=CPU Clock)</p>																		
P0.0 – P0.15	98 – 5 8 – 15	I/O	<p>Port 0 is a 16-bit bidirectional IO port. It is bit-wise programmable for input or output via direction bits. For a pin configured as input, the output driver is put into high-impedance state.</p> <p>In case of an external bus configuration, Port 0 serves as the address (A) and address/data (AD) bus in multiplexed bus modes and as the data (D) bus in demultiplexed bus modes.</p> <p>Demultiplexed bus modes:</p> <table> <tr> <td>Data Path Width:</td> <td>8-bit</td> <td>16-bit</td> </tr> <tr> <td>P0.0 – P0.7:</td> <td>D0 – D7</td> <td>D0 - D7</td> </tr> <tr> <td>P0.8 – P0.15:</td> <td>output!</td> <td>D8 - D15</td> </tr> </table> <p>Multiplexed bus modes:</p> <table> <tr> <td>Data Path Width:</td> <td>8-bit</td> <td>16-bit</td> </tr> <tr> <td>P0.0 – P0.7:</td> <td>AD0 – AD7</td> <td>AD0 - AD7</td> </tr> <tr> <td>P0.8 – P0.15:</td> <td>A8 - A15</td> <td>AD8 - AD15</td> </tr> </table>	Data Path Width:	8-bit	16-bit	P0.0 – P0.7:	D0 – D7	D0 - D7	P0.8 – P0.15:	output!	D8 - D15	Data Path Width:	8-bit	16-bit	P0.0 – P0.7:	AD0 – AD7	AD0 - AD7	P0.8 – P0.15:	A8 - A15	AD8 - AD15
Data Path Width:	8-bit	16-bit																			
P0.0 – P0.7:	D0 – D7	D0 - D7																			
P0.8 – P0.15:	output!	D8 - D15																			
Data Path Width:	8-bit	16-bit																			
P0.0 – P0.7:	AD0 – AD7	AD0 - AD7																			
P0.8 – P0.15:	A8 - A15	AD8 - AD15																			
V_{AREF}	54	-	Reference voltage for the A/D converter.																		
V_{AGND}	55	-	Reference ground for the A/D converter.																		

Pin Definitions and Functions (cont'd)

Symbol	Pin Number	Input Output	Function
V_{CC}	7, 18, 38, 61, 79, 93	-	Digital Supply Voltage: + 5 V during normal operation and idle mode. ≥ 2.5 V during power down mode
V_{SS}	6, 21, 39, 60, 78, 94	-	Digital Ground.

Functional Description

The architecture of the SAB 80C166 combines advantages of both RISC and CISC processors and of advanced peripheral subsystems in a very well-balanced way. The following block diagram gives an overview of the different on-chip components and of the advanced, high bandwidth internal bus structure of the SAB 80C166.

Note: All time specifications refer to a CPU clock of 20 MHz
(see definition in the AC Characteristics section).

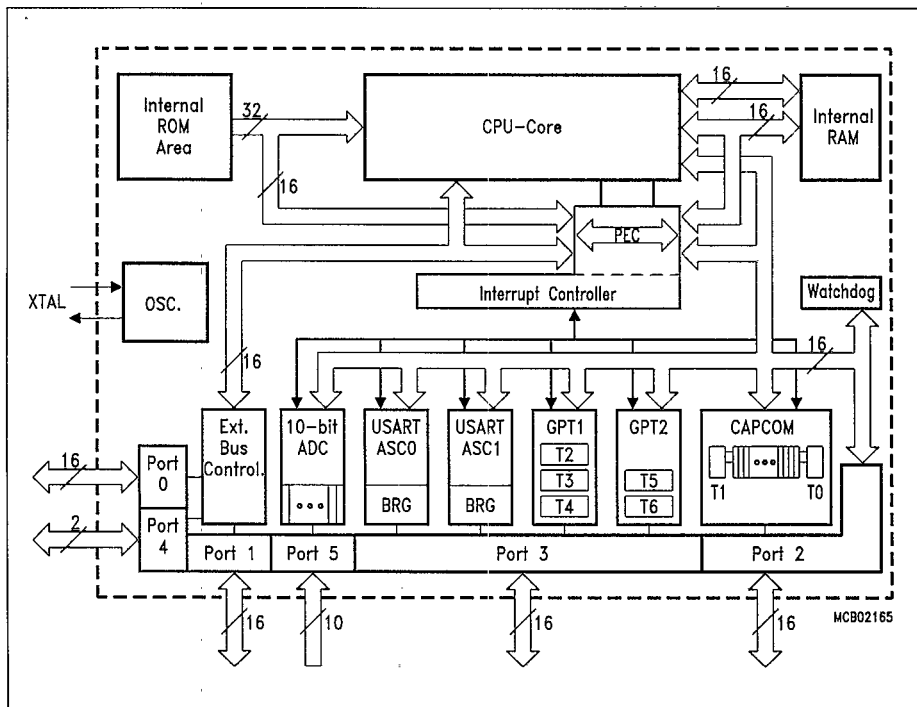

Figure 3
Block Diagram

Memory Organization

The memory space of the SAB 80C166 is configured in a Von Neumann architecture which means that code memory, data memory, registers and I/O ports are organized within the same linear address space which includes 256 KBytes. Address space expansion to 16 MBytes is provided for future versions. The entire memory space can be accessed byte-wise or word-wise. Particular portions of the on-chip memory have additionally been made directly bit addressable.

The SAB 83C166 contains 32 KBytes of on-chip mask-programmable ROM for code or constant data. The ROM can be mapped to either segment 0 or segment 1.

1 KByte of on-chip RAM is provided as a storage for user defined variables, for the system stack, general purpose register banks and even for code. A register bank can consist of up to 16 word-wide (R0 to R15) and/or byte-wide (RL0, RH0, ..., RL7, RH7) so-called General Purpose Registers (GPRs).

512 bytes of the address space are reserved for the Special Function Register area. SFRs are word-wide registers which are used for controlling and monitoring functions of the different on-chip units. 98 SFRs are currently implemented. Unused SFR addresses are reserved for future members of the SAB 80C166 family.

In order to meet the needs of designs where more memory is required than is provided on chip, up to 256 KBytes of external RAM and/or ROM can be connected to the microcontroller.

External Bus Controller

All of the external memory accesses are performed by a particular on-chip External Bus Controller (EBC). It can be programmed either to Single Chip Mode when no external memory is required, or to one of four different external memory access modes, which are as follows:

- 16-/18-bit Addresses, 16-bit Data, Demultiplexed
- 16-/18-bit Addresses, 16-bit Data, Multiplexed
- 16-/18-bit Addresses, 8-bit Data, Multiplexed
- 16-/18-bit Addresses, 8-bit Data, Demultiplexed

In the demultiplexed bus modes, addresses are output on Port 1 and data is input/output on Port 0. In the multiplexed bus modes both addresses and data use Port 0 for input/output.

Important timing characteristics of the external bus interface (Memory Cycle Time, Memory Tri-State Time, Read/Write Delay and Length of ALE, i.e. address setup/hold time with respect to ALE) have been made programmable to allow the user the adaption of a wide range of different types of memories. In addition, different address ranges may be accessed with different bus characteristics. Access to very slow memories is supported via a particular 'Ready' function. A HOLD/HLDA protocol is available for bus arbitration.

For applications which require less than 64 KBytes of external memory space, a non-segmented memory model can be selected. In this case all memory locations can be addressed by 16 bits and Port 4 is not required to output the additional segment address lines.

Central Processing Unit (CPU)

The main core of the CPU consists of a 4-stage instruction pipeline, a 16-bit arithmetic and logic unit (ALU) and dedicated SFRs. Additional hardware has been spent for a separate multiply and divide unit, a bit-mask generator and a barrel shifter.

Based on these hardware provisions, most of the SAB 80C166's instructions can be executed in just one machine cycle which requires 100 ns at 20-MHz CPU clock. For example, shift and rotate instructions are always processed during one machine cycle independent of the number of bits to be shifted. All multiple-cycle instructions have been optimized so that they can be executed very fast as well: branches in 2 cycles, a 16 × 16 bit multiplication in 5 cycles and a 32-/16 bit division in 10 cycles. Another pipeline optimization, the so-called 'Jump Cache', allows reducing the execution time of repeatedly performed jumps in a loop from 2 cycles to 1 cycle.

The CPU disposes of an actual register context consisting of up to 16 wordwide GPRs which are physically allocated within the on-chip RAM area. A Context Pointer (CP) register determines the base address of the active register bank to be accessed by the CPU at a time. The number of register banks is only restricted by the available internal RAM space. For easy parameter passing, a register bank may overlap others.

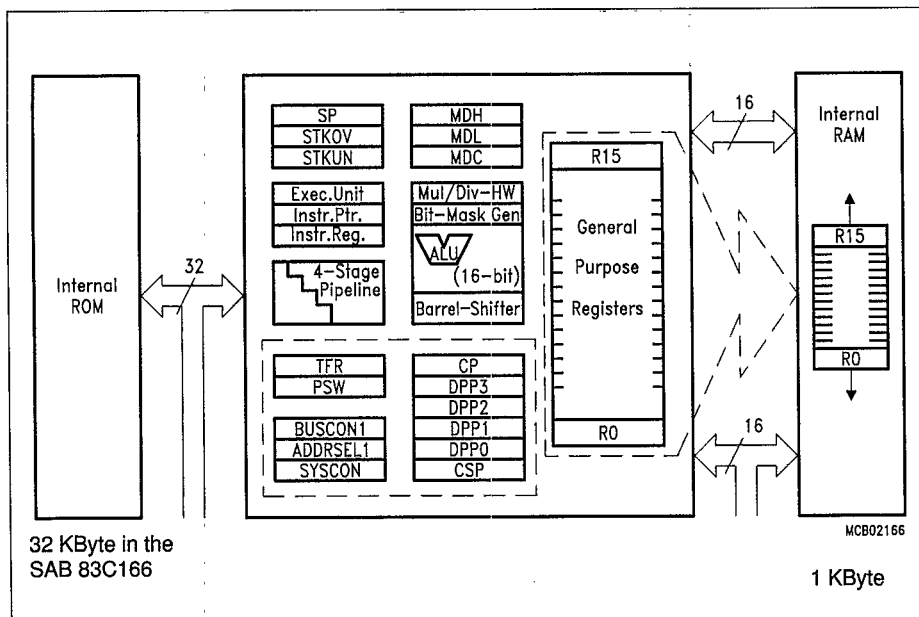

Figure 4
CPU Block Diagram

A system stack of up to 512 bytes is provided as a storage for temporary data. The system stack is allocated in the on-chip RAM area, and it is accessed by the CPU via the stack pointer (SP) register. Two separate SFRs, STKOV and STKUN, are implicitly compared against the stack pointer value upon each stack access for the detection of a stack overflow or underflow.

The high performance offered by the hardware implementation of the CPU can efficiently be utilized by a programmer via the highly efficient SAB 80C166 instruction set which includes the following instruction classes:

- Arithmetic Instructions
- Logical Instructions
- Boolean Bit Manipulation Instructions
- Compare and Loop Control Instructions
- Shift and Rotate Instructions
- Prioritize Instruction
- Data Movement Instructions
- System Stack Instructions
- Jump and Call Instructions
- Return Instructions
- System Control Instructions
- Miscellaneous Instructions

The basic instruction length is either 2 or 4 bytes. Possible operand types are bits, bytes and words. A variety of direct, indirect or immediate addressing modes are provided to specify the required operands.

Interrupt System

With an interrupt response time within a range from just 250 ns to 600 ns (in case of internal program execution), the SAB 80C166 is capable of reacting very fast to the occurrence of non-deterministic events.

The architecture of the SAB 80C166 supports several mechanisms for fast and flexible response to service requests that can be generated from various sources internal or external to the microcontroller. Any of these interrupt requests can be programmed to being serviced by the Interrupt Controller or by the Peripheral Event Controller (PEC).

In contrast to a standard interrupt service where the current program execution is suspended and a branch to the interrupt vector table is performed, just one cycle is 'stolen' from the current CPU activity to perform a PEC service. A PEC service implies a single byte or word data transfer between any two memory locations with an additional increment of either the PEC source or the destination pointer. An individual PEC transfer counter is implicitly decremented for each PEC service except when performing in the continuous transfer mode. When this counter reaches zero, a standard interrupt is performed to the corresponding source related vector location. PEC services are very well suited, for example, for supporting the transmission or reception of blocks of data, or for transferring A/D converted results to a memory table. The SAB 80C166 has 8 PEC channels each of which offers such fast interrupt-driven data transfer capabilities.

A separate control register which contains an interrupt request flag, an interrupt enable flag and an interrupt priority bitfield exists for each of the possible interrupt sources. Via its related register, each source can be programmed to one of sixteen interrupt priority levels. Once having been accepted by the CPU, an interrupt service can only be interrupted by a higher prioritized service request. For the standard interrupt processing, each of the possible interrupt sources has a dedicated vector location.

Software interrupts are supported by means of the 'TRAP' instruction in combination with an individual trap (interrupt) number.

The following table shows all of the possible SAB 80C166 interrupt sources and the corresponding hardware-related interrupt flags, vectors, vector locations and trap (interrupt) numbers:

Source of Interrupt or PEC Service Request	Request Flag	Enable Flag	Interrupt Vector	Vector Location	Trap Number
CAPCOM Register 0	CC0IR	CC0IE	CC0INT	40 _H	10 _H
CAPCOM Register 1	CC1IR	CC1IE	CC1INT	44 _H	11 _H
CAPCOM Register 2	CC2IR	CC2IE	CC2INT	48 _H	12 _H
CAPCOM Register 3	CC3IR	CC3IE	CC3INT	4C _H	13 _H
CAPCOM Register 4	CC4IR	CC4IE	CC4INT	50 _H	14 _H
CAPCOM Register 5	CC5IR	CC5IE	CC5INT	54 _H	15 _H
CAPCOM Register 6	CC6IR	CC6IE	CC6INT	58 _H	16 _H
CAPCOM Register 7	CC7IR	CC7IE	CC7INT	5C _H	17 _H
CAPCOM Register 8	CC8IR	CC8IE	CC8INT	60 _H	18 _H
CAPCOM Register 9	CC9IR	CC9IE	CC9INT	64 _H	19 _H
CAPCOM Register 10	CC10IR	CC10IE	CC10INT	68 _H	1A _H
CAPCOM Register 11	CC11IR	CC11IE	CC11INT	6C _H	1B _H
CAPCOM Register 12	CC12IR	CC12IE	CC12INT	70 _H	1C _H
CAPCOM Register 13	CC13IR	CC13IE	CC13INT	74 _H	1D _H
CAPCOM Register 14	CC14IR	CC14IE	CC14INT	78 _H	1E _H
CAPCOM Register 15	CC15IR	CC15IE	CC15INT	7C _H	1F _H
CAPCOM Timer 0	T0IR	T0IE	T0INT	80 _H	20 _H
CAPCOM Timer 1	T1IR	T1IE	T1INT	84 _H	21 _H
GPT1 Timer 2	T2IR	T2IE	T2INT	88 _H	22 _H
GPT1 Timer 3	T3IR	T3IE	T3INT	8C _H	23 _H
GPT1 Timer 4	T4IR	T4IE	T4INT	90 _H	24 _H
GPT2 Timer 5	T5IR	T5IE	T5INT	94 _H	25 _H
GPT2 Timer 6	T6IR	T6IE	T6INT	98 _H	26 _H
GPT2 CAPREL Register	CRIR	CRIE	CRINT	9C _H	27 _H
A/D Conversion Complete	ADCIR	ADCIE	ADCINT	A0 _H	28 _H
A/D Overrun Error	ADEIR	ADEIE	ADEINT	A4 _H	29 _H
ASC0 Transmit	S0TIR	S0TIE	S0TINT	A8 _H	2A _H
ASC0 Receive	S0RIR	S0RIE	S0RINT	AC _H	2B _H
ASC0 Error	S0EIR	S0EIE	S0EINT	B0 _H	2C _H
ASC1 Transmit	S1TIR	S1TIE	S1TINT	B4 _H	2D _H
ASC1 Receive	S1RIR	S1RIE	S1RINT	B8 _H	2E _H
ASC1 Error	S1EIR	S1EIE	S1EINT	BC _H	2F _H

The SAB 80C166 also provides an excellent mechanism to identify and to process exceptions or error conditions that arise during run-time, so-called 'Hardware Traps'. Hardware traps cause immediate non-maskable system reaction which is similar to a standard interrupt service (branching to a dedicated vector table location). The occurrence of a hardware trap is additionally signified by an individual bit in the trap flag register (TFR). Except when another higher prioritized trap service is in progress, a hardware trap will interrupt any actual program execution. In turn, hardware trap services can normally not be interrupted by standard or PEC interrupts.

The following table shows all of the possible exceptions or error conditions that can arise during run-time:

Exception Condition	Trap Flag	Trap Vector	Vector Location	Trap Number	Trap Priority
Reset Functions:					
Hardware Reset		RESET	0000 _H	00 _H	III
Software Reset		RESET	0000 _H	00 _H	III
Watchdog Timer Overflow		RESET	0000 _H	00 _H	III
Class A Hardware Traps:					
Non-Maskable Interrupt	NMI	NMITRAP	0008 _H	02 _H	II
Stack Overflow	STKOF	STOTRAP	0010 _H	04 _H	II
Stack Underflow	STKUF	STUTRAP	0018 _H	06 _H	II
Class B Hardware Traps:					
Undefined Opcode	UNDOPC	BTRAP	0028 _H	0A _H	I
Protected Instruction Fault	PRTFLT	BTRAP	0028 _H	0A _H	I
Illegal Word Operand Access	ILLOPA	BTRAP	0028 _H	0A _H	I
Illegal Instruction Access	ILLINA	BTRAP	0028 _H	0A _H	I
Illegal External Bus Access	ILLBUS	BTRAP	0028 _H	0A _H	I
Reserved			[002C _H – 003C _H]	[0B _H – 0F _H]	
Software Traps					
TRAP Instruction			Any [0000 _H – 01FC _H] in steps of 04 _H	Any [00 _H – 7F _H]	Current CPU Priority

Capture/Compare (CAPCOM) Unit

The CAPCOM unit supports generation and control of timing sequences on up to 16 channels with a maximum resolution of 400 ns (@ 20 MHz CPU clock). The CAPCOM unit is typically used to handle high speed I/O tasks such as pulse and waveform generation, pulse width modulation (PMW), Digital to Analog (D/A) conversion, software timing, or time recording relative to external events.

Two 16-bit timers (T0/T1) with reload registers provide two independent time bases for the capture/compare register array.

The input clock for the timers is programmable to several prescaled values of the CPU clock, or may be derived from an overflow/underflow of timer T6 in module GPT2. This provides a wide range of variation for the timer period and resolution and allows precise adjustments to the application specific requirements. In addition, an external count input for CAPCOM timer T0 allows event scheduling for the capture/compare registers relative to external events.

The capture/compare register array contains 16 dual purpose capture/compare registers, each of which may be individually allocated to either CAPCOM timer T0 or T1, and programmed for capture or compare function. Each register has one port pin associated with it which serves as an input pin for triggering the capture function, or as an output pin to indicate the occurrence of a compare event.

When a capture/compare register has been selected for capture mode, the current contents of the allocated timer will be latched (captured) into the capture/compare register in response to an external event at the port pin which is associated with this register. In addition, a specific interrupt request for this capture/compare register is generated. Either a positive, a negative, or both a positive and a negative external signal transition at the pin can be selected as the triggering event. The contents of all registers which have been selected for one of the five compare modes are continuously compared with the contents of the allocated timers. When a match occurs between the timer value and the value in a capture/compare register, specific actions will be taken based on the selected compare mode.

Compare Modes	Function
Mode 0	Interrupt-only compare mode; several compare interrupts per timer period are possible
Mode 1	Pin toggles on each compare match; several compare events per timer period are possible
Mode 2	Interrupt-only compare mode; only one compare interrupt per timer period is generated
Mode 3	Pin set '1' on match; pin reset '0' on compare time overflow; only one compare event per timer period is generated
Double Register Mode	Two registers operate on one pin; pin toggles on each compare match; several compare events per timer period are possible.

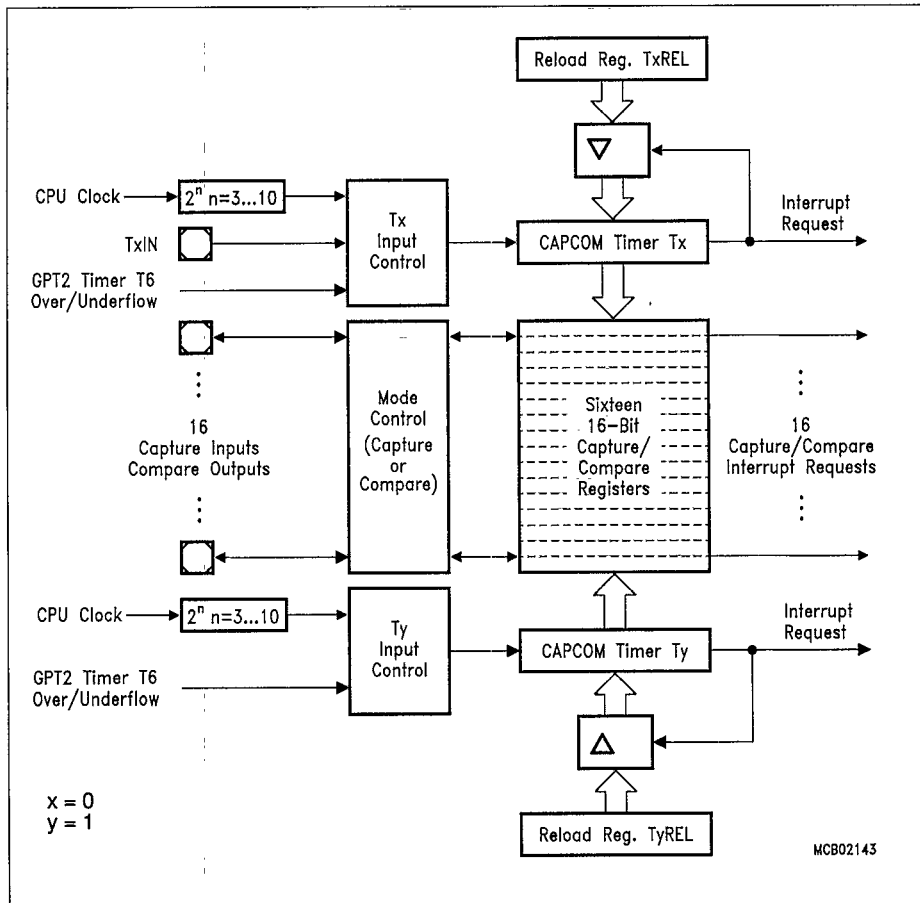

Figure 5
CAPCOM Unit Block Diagram

General Purpose Timer (GPT) Unit

The GPT unit represents a very flexible multifunctional timer/counter structure which may be used for many different time related tasks such as event timing and counting, pulse width and duty cycle measurements, pulse generation, or pulse multiplication.

The GPT unit incorporates five 16-bit timers which are organized in two separate modules, GPT1 and GPT2. Each timer in each module may operate independently in a number of different modes, or may be concatenated with another timer of the same module.

Each of the three timers T2, T3, T4 of module GPT1 can be configured individually for one of three basic modes of operation, which are Timer, Gated Timer, and Counter Mode. In Timer Mode, the input clock for a timer is derived from the CPU clock, divided by a programmable prescaler, while Counter Mode allows a timer to be clocked in reference to external events.

Pulse width or duty cycle measurement is supported in Gated Timer Mode, where the operation of a timer is controlled by the 'gate' level on an external input pin. For these purposes, each timer has one associated port pin (TxIN) which serves as gate or clock input. The maximum resolution of the timers in module GPT1 is 400 ns (@ 20 MHz CPU clock).

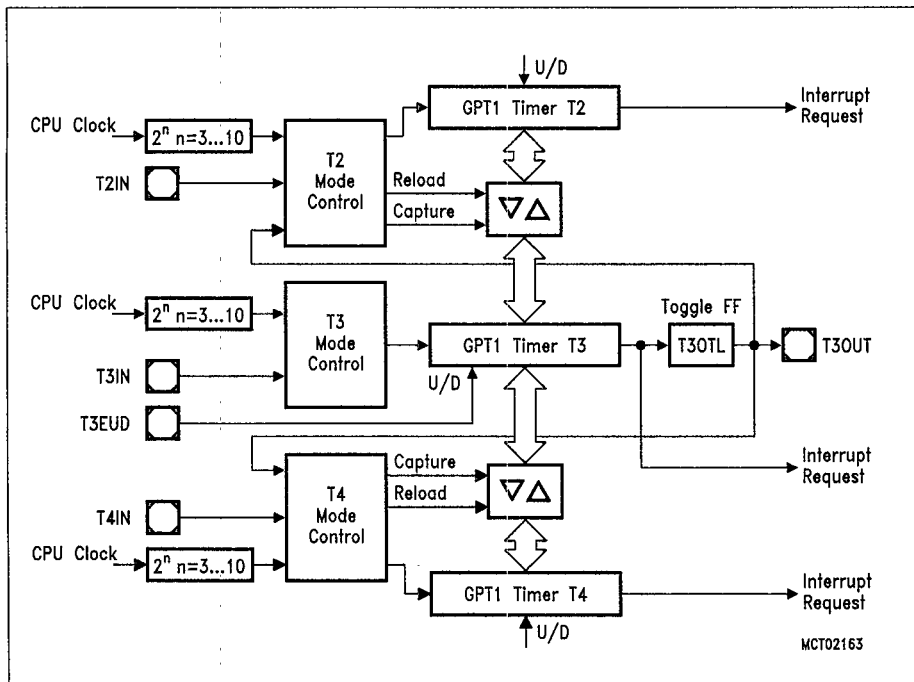

Figure 6
Block Diagram of GPT1

The count direction (up/down) for each timer is programmable by software. For timer T3 the count direction may additionally be altered dynamically by an external signal on a port pin (T3EUD) to facilitate e. g. position tracking.

Timer T3 has an output toggle latch (T3OTL) which changes its state on each timer over-flow/underflow. The state of this latch may be output on a port pin (T3OUT) e. g. for timeout monitoring of external hardware components, or may be used internally to clock timers T2 and T4 for measuring long time periods with high resolution.

In addition to their basic operating modes, timers T2 and T4 may be configured as reload or capture registers for timer T3. When used as capture or reload registers, timers T2 and T4 are stopped. The contents of timer T3 is captured into T2 or T4 in response to a signal at their associated input pins (TxIN). Timer T3 is reloaded with the contents of T2 or T4 triggered either by an external signal or by a selectable state transition of its toggle latch T3OTL. When both T2 and T4 are configured to alternately reload T3 on opposite state transitions of T3OTL with the low and high times of a PWM signal, this signal can be constantly generated without software intervention.

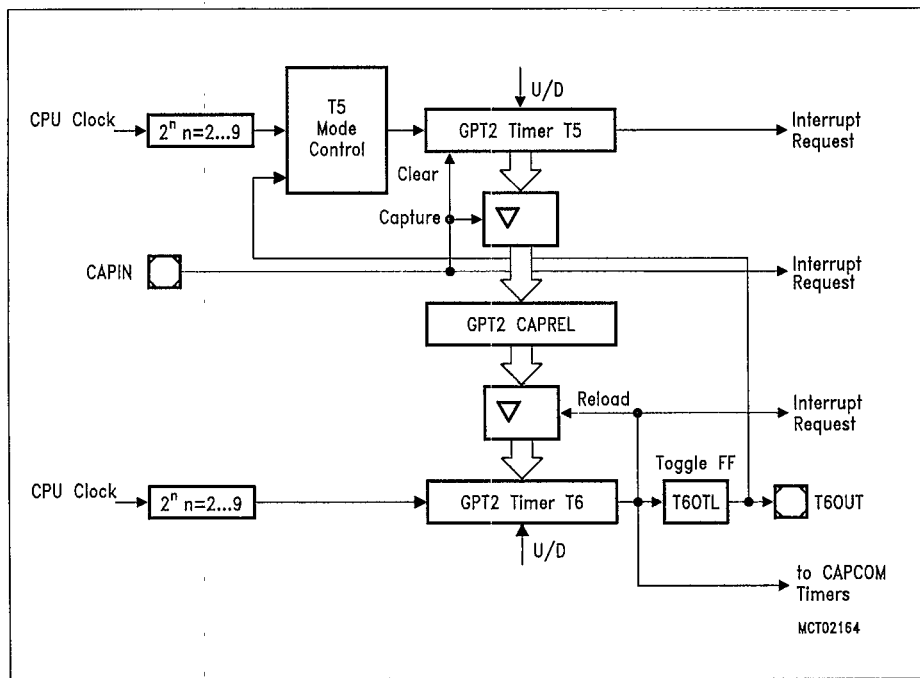

Figure 7
Block Diagram of GPT2

With its maximum resolution of 200 ns (@ 20 MHz), the GPT2 module provides precise event control and time measurement. It includes two timers (T5, T6) and a capture/reload register (CAPREL). Both timers can be clocked with an input clock which is derived from the CPU clock via a programmable prescaler. The count direction (up/down) for each timer is programmable by software. Concatenation of the timers is supported via the output toggle latch (T6OTL) of timer T6, which changes its state on each timer overflow/underflow.

The state of this latch may be used to clock timer T5, or it may be output on a port pin (T6OUT). The overflows/underflows of timer T6 can additionally be used to clock the CAPCOM timers T0 or T1, and to cause a reload from the CAPREL register. The CAPREL register may capture the contents of timer T5 based on an external signal transition on the corresponding port pin (CAPIN), and timer T5 may optionally be cleared after the capture procedure. This allows absolute time differences to be measured or pulse multiplication to be performed without software overhead.

A/D Converter

For analog signal measurement, a 10-bit A/D converter with 10 multiplexed input channels and a sample and hold circuit has been integrated on-chip. It uses the method of successive approximation. The sample time (for loading the capacitors) and the conversion time adds up to 9.7 us @ 20 MHz CPU clock.

Overrun error detection/protection is provided for the conversion result register (ADDAT): an interrupt request will be generated when the result of a previous conversion has not been read from the result register at the time the next conversion is complete.

For applications which require less than 10 analog input channels, the remaining channel inputs can be used as digital input port pins.

The A/D converter of the SAB 80C166 supports four different conversion modes. In the standard Single Channel conversion mode, the analog level on a specified channel is sampled once and converted to a digital result. In the Single Channel Continuous mode, the analog level on a specified channel is repeatedly sampled and converted without software intervention. In the Auto Scan mode, the analog levels on a prespecified number of channels are sequentially sampled and converted. In the Auto Scan Continuous mode, the number of prespecified channels is repeatedly sampled and converted.

The Peripheral Event Controller (PEC) may be used to automatically store the conversion results into a table in memory for later evaluation, without requiring the overhead of entering and exiting interrupt routines for each data transfer.

Parallel Ports

The SAB 80C166 provides up to 76 I/O lines which are organized into five input/output ports and one input port. All port lines are bit-addressable, and all input/output lines are individually (bit-wise) programmable as inputs or outputs via direction registers. The I/O ports are true bidirectional ports which are switched to high impedance state when configured as inputs. During the internal reset, all port pins are configured as inputs.

All port lines have programmable alternate input or output functions associated with them. Port 0 and Port 1 may be used as address and data lines when accessing external memory, while Port 4 outputs the additional segment address bits A17/A16 in systems where segmentation is enabled to access more than 64 KBytes of memory. Port 2 is associated with the capture inputs or compare outputs of the CAPCOM unit and/or with optional bus arbitration signals (BREQ, HLDA, HOLD). Port 3 includes alternate functions of timers, serial interfaces, optional bus control signals (WR, BHE, READY) and the system clock output (CLKOUT). Port 5 is used for the analog input channels to the A/D converter. All port lines that are not used for these alternate functions may be used as general purpose I/O lines.

Serial Channels

Serial communication with other microcontrollers, processors, terminals or external peripheral components is provided by two serial interfaces with identical functionality, Asynchronous/Synchronous Serial Channels ASC0 and ASC1.

They are upward compatible with the serial ports of the Siemens SAB 8051x microcontroller family and support full-duplex asynchronous communication up to 625 Kbaud and half-duplex synchronous communication up to 2.5 Mbaud @ 20 MHz CPU clock.

Two dedicated baud rate generators allow to set up all standard baud rates without oscillator tuning. For transmission, reception, and erroneous reception 3 separate interrupt vectors are provided for each serial channel.

In asynchronous mode, 8- or 9-bit data frames are transmitted or received, preceded by a start bit and terminated by one or two stop bits. For multiprocessor communication, a mechanism to distinguish address from data bytes has been included (8-bit data + wake up bit mode).

In synchronous mode one data byte is transmitted or received synchronously to a shift clock which is generated by the SAB 80C166.

A loop back option is available for testing purposes.

A number of optional hardware error detection capabilities has been included to increase the reliability of data transfers. A parity bit can automatically be generated on transmission or be checked on reception. Framing error detection allows to recognize data frames with missing stop bits. An overrun error will be generated, if the last character received has not been read out of the receive buffer register at the time the reception of a new character is complete.

Watchdog Timer

The Watchdog Timer represents one of the fail-safe mechanisms which have been implemented to prevent the controller from malfunctioning for longer periods of time.

The Watchdog Timer is always enabled after a reset of the chip, and can only be disabled in the time interval until the EINIT (end of initialization) instruction has been executed. Thus, the chip's start-up procedure is always monitored. The software has to be designed to service the Watchdog Timer before it overflows. If, due to hardware or software related failures, the software fails to do so, the Watchdog Timer overflows and generates an internal hardware reset and pulls the $\overline{\text{RSTOUT}}$ pin low in order to allow external hardware components to be reset.

The Watchdog Timer is a 16-bit timer, clocked with the CPU clock divided either by 2 or by 128. The high byte of the Watchdog Timer register can be set to a prespecified reload value (stored in WDTRRL) in order to allow further variation of the monitored time interval. Each time it is serviced by the application software, the high byte of the Watchdog Timer is reloaded. Thus, time intervals between 25 μs and 420 ms can be monitored (@ 20 MHz CPU clock). The default Watchdog Timer interval after reset is 6.55 ms (@ 20 MHz CPU clock).

Bootstrap Loader

The SAB 80C166 provides a built-in bootstrap loader (BSL), which allows to start program execution out of the SAB 80C166's internal RAM. The program to be started is loaded via the serial interface ASC0 and does not require external memory or an internal ROM.

The SAB 80C166 enters BSL mode, when ALE is sampled high at the end of a hardware reset and if $\overline{\text{NMI}}$ becomes active directly after the end of the internal reset sequence. BSL mode is entered independent of the bus mode selected via EBC0, EBC1 and $\overline{\text{BUSACT}}$.

After entering BSL mode the SAB 80C166 scans the RXD0 line to receive a zero byte, i.e. one start bit, eight '0' data bits and one stop bit. From the duration of this zero byte it calculates the corresponding baudrate factor with respect to the current CPU clock and initializes ASC0 accordingly. Using this baudrate, an acknowledge byte is returned to the host that provides the loaded data. The SAB 80C166 returns the value <55_H>.

The next 32 bytes received via ASC0 are stored sequentially into locations 0FA40_H through 0FA5F_H of the internal RAM. To execute the loaded code the BSL then jumps to location 0FA40_H. The loaded program may load additional code / data, change modes, etc.

The SAB 80C166 exits BSL mode upon a software reset (ignores the ALE level) or a hardware reset (remove conditions for entering BSL mode before).

Instruction Set Summary

The table below lists the instructions of the SAB 80C166 in a condensed way. The various addressing modes that can be used with a specific instruction, the operation of the instructions, parameters for conditional execution of instructions, and the opcodes for each instruction can be found in the "C16x Family Instruction Set Manual".

This document also provides a detailed description of each instruction.

Instruction Set Summary

Mnemonic	Description	Bytes
ADD(B)	Add word (byte) operands	2 / 4
ADDC(B)	Add word (byte) operands with Carry	2 / 4
SUB(B)	Subtract word (byte) operands	2 / 4
SUBC(B)	Subtract word (byte) operands with Carry	2 / 4
MUL(U)	(Un)Signed multiply direct GPR by direct GPR (16-/16-bit)	2
DIV(U)	(Un)Signed divide register MDL by direct GPR (16-/16-bit)	2
DIVL(U)	(Un)Signed long divide reg. MD by direct GPR (32-/16-bit)	2
CPL(B)	Complement direct word (byte) GPR	2
NEG(B)	Negate direct word (byte) GPR	2
AND(B)	Bitwise AND, (word/byte operands)	2 / 4
OR(B)	Bitwise OR, (word/byte operands)	2 / 4
XOR(B)	Bitwise XOR, (word/byte operands)	2 / 4
BCLR	Clear direct bit	2
BSET	Set direct bit	2
BMOV(N)	Move (negated) direct bit to direct bit	4
BAND, BOR, BXOR	AND/OR/XOR direct bit with direct bit	4
BCMP	Compare direct bit to direct bit	4
BFLDH/L	Bitwise modify masked high/low byte of bit-addressable direct word memory with immediate data	4
CMP(B)	Compare word (byte) operands	2 / 4
CMPD1/2	Compare word data to GPR and decrement GPR by 1/2	2 / 4
CMPI1/2	Compare word data to GPR and increment GPR by 1/2	2 / 4
PRIOR	Determine number of shift cycles to normalize direct word GPR and store result in direct word GPR	2
SHL / SHR	Shift left/right direct word GPR	2
ROL / ROR	Rotate left/right direct word GPR	2
ASHR	Arithmetic (sign bit) shift right direct word GPR	2

Instruction Set Summary (cont'd)

Mnemonic	Description	Bytes
MOV(B)	Move word (byte) data	2 / 4
MOVBS	Move byte operand to word operand with sign extension	2 / 4
MOVZ	Move byte operand to word operand. with zero extension	2 / 4
JMPA, JMPI, JMPR	Jump absolute/indirect/relative if condition is met	4
JMPS	Jump absolute to a code segment	4
J(N)B	Jump relative if direct bit is (not) set	4
JBC	Jump relative and clear bit if direct bit is set	4
JNBS	Jump relative and set bit if direct bit is not set	4
CALLA, CALLI, CALLR	Call absolute/indirect/relative subroutine if condition is met	4
CALLS	Call absolute subroutine in any code segment	4
PCALL	Push direct word register onto system stack and call absolute subroutine	4
TRAP	Call interrupt service routine via immediate trap number	2
PUSH, POP	Push/pop direct word register onto/from system stack	2
SCXT	Push direct word register onto system stack and update register with word operand	4
RET	Return from intra-segment subroutine	2
RETS	Return from inter-segment subroutine	2
RETP	Return from intra-segment subroutine and pop direct word register from system stack	2
RETI	Return from interrupt service subroutine	2
SRST	Software Reset	4
IDLE	Enter Idle Mode	4
PWRDN	Enter Power Down Mode (supposes NMI-pin being low)	4
SRVWDT	Service Watchdog Timer	4
DISWDT	Disable Watchdog Timer	4
EINIT	Signify End-of-Initialization on RSTOUT-pin	4
NOP	Null operation	2

Special Function Registers Overview

The following table lists all SFRs which are implemented in the SAB 80C166 in alphabetical order. Bit-addressable SFRs are marked with the letter "b" in column "Name".

An SFR can be specified via its individual mnemonic name. Depending on the selected addressing mode, an SFR can be accessed via its physical address (using the Data Page Pointers), or via its short 8-bit address (without using the Data Page Pointers).

Special Function Registers Overview

Name	Physical Address	8-Bit Address	Description	Reset Value
ADCIC	b FF98 _H	CC _H	A/D Converter End of Conversion Interrupt Control Register	0000 _H
ADCON	b FFA0 _H	D0 _H	A/D Converter Control Register	0000 _H
ADDAT	FEA0 _H	50 _H	A/D Converter Result Register	0000 _H
ADDRSEL1	FE18 _H	0C _H	Address Select Register 1	0000 _H
ADEIC	b FF9A _H	CD _H	A/D Converter Overrun Error Interrupt Control Register	0000 _H
BUSCON1	b FF14 _H	8A _H	Bus Configuration Register 1	0000 _H
CAPREL	FE4A _H	25 _H	GPT2 Capture/Reload Register	0000 _H
CC0	FE80 _H	40 _H	CAPCOM Register 0	0000 _H
CC0IC	b FF78 _H	BC _H	CAPCOM Register 0 Interrupt Control Register	0000 _H
CC1	FE82 _H	41 _H	CAPCOM Register 1	0000 _H
CC1IC	b FF7A _H	BD _H	CAPCOM Register 1 Interrupt Control Register	0000 _H
CC2	FE84 _H	42 _H	CAPCOM Register 2	0000 _H
CC2IC	b FF7C _H	BE _H	CAPCOM Register 2 Interrupt Control Register	0000 _H
CC3	FE86 _H	43 _H	CAPCOM Register 3	0000 _H
CC3IC	b FF7E _H	BF _H	CAPCOM Register 3 Interrupt Control Register	0000 _H
CC4	FE88 _H	44 _H	CAPCOM Register 4	0000 _H
CC4IC	b FF80 _H	C0 _H	CAPCOM Register 4 Interrupt Control Register	0000 _H
CC5	FE8A _H	45 _H	CAPCOM Register 5	0000 _H
CC5IC	b FF82 _H	C1 _H	CAPCOM Register 5 Interrupt Control Register	0000 _H
CC6	FE8C _H	46 _H	CAPCOM Register 6	0000 _H
CC6IC	b FF84 _H	C2 _H	CAPCOM Register 6 Interrupt Control Register	0000 _H
CC7	FE8E _H	47 _H	CAPCOM Register 7	0000 _H

Special Function Registers Overview (cont'd)

Name	Physical Address	8-Bit Address	Description	Reset Value
DPP0	FE00 _H	00 _H	CPU Data Page Pointer 0 Register (4 bits)	0000 _H
DPP1	FE02 _H	01 _H	CPU Data Page Pointer 1 Register (4 bits)	0001 _H
DPP2	FE04 _H	02 _H	CPU Data Page Pointer 2 Register (4 bits)	0002 _H
DPP3	FE06 _H	03 _H	CPU Data Page Pointer 3 Register (4 bits)	0003 _H
MDC	b FF0E _H	87 _H	CPU Multiply / Divide Control Register	0000 _H
MDH	FE0C _H	06 _H	CPU Multiply / Divide Register – High Word	0000 _H
MDL	FE0E _H	07 _H	CPU Multiply / Divide Register – Low Word	0000 _H
ONES	FF1E _H	8F _H	Constant Value 1's Register (read only)	FFFF _H
P0	b FF00 _H	80 _H	Port 0 Register	0000 _H
P1	b FF04 _H	82 _H	Port 1 Register	0000 _H
P2	b FFC0 _H	E0 _H	Port 2 Register	0000 _H
P3	b FFC4 _H	E2 _H	Port 3 Register	0000 _H
P4	b FFC8 _H	E4 _H	Port 4 Register (2 bits)	00 _H
P5	b FFA2 _H	D1 _H	Port 5 Register (read only)	XXXX _H
PECC0	FEC0 _H	60 _H	PEC Channel 0 Control Register	0000 _H
PECC1	FEC2 _H	61 _H	PEC Channel 1 Control Register	0000 _H
PECC2	FEC4 _H	62 _H	PEC Channel 2 Control Register	0000 _H
PECC3	FEC6 _H	63 _H	PEC Channel 3 Control Register	0000 _H
PECC4	FEC8 _H	64 _H	PEC Channel 4 Control Register	0000 _H
PECC5	FECA _H	65 _H	PEC Channel 5 Control Register	0000 _H
PECC6	FEC _H	66 _H	PEC Channel 6 Control Register	0000 _H
PECC7	FECE _H	67 _H	PEC Channel 7 Control Register	0000 _H
PSW	b FF10 _H	88 _H	CPU Program Status Word	0000 _H
S0BG	FEB4 _H	5A _H	Serial Channel 0 Baud Rate Generator Reload Register	0000 _H
S0CON	b FFB0 _H	D8 _H	Serial Channel 0 Control Register	0000 _H
S0EIC	b FF70 _H	B8 _H	Serial Channel 0 Error Interrupt Control Register	0000 _H
S0RBUF	FEB2 _H	59 _H	Serial Channel 0 Receive Buffer Register (read only)	XX _H

Special Function Registers Overview (cont'd)

Name	Physical Address	8-Bit Address	Description	Reset Value
CC7IC	b FF86 _H	C3 _H	CAPCOM Register 7 Interrupt Control Register	0000 _H
CC8	FE90 _H	48 _H	CAPCOM Register 8	0000 _H
CC8IC	b FF88 _H	C4 _H	CAPCOM Register 8 Interrupt Control Register	0000 _H
CC9	FE92 _H	49 _H	CAPCOM Register 9	0000 _H
CC9IC	b FF8A _H	C5 _H	CAPCOM Register 9 Interrupt Control Register	0000 _H
CC10	FE94 _H	4A _H	CAPCOM Register 10	0000 _H
CC10IC	b FF8C _H	C6 _H	CAPCOM Register 10 Interrupt Control Register	0000 _H
CC11	FE96 _H	4B _H	CAPCOM Register 11	0000 _H
CC11IC	b FF8E _H	C7 _H	CAPCOM Register 11 Interrupt Control Register	0000 _H
CC12	FE98 _H	4C _H	CAPCOM Register 12	0000 _H
CC12IC	b FF90 _H	C8 _H	CAPCOM Register 12 Interrupt Control Register	0000 _H
CC13	FE9A _H	4D _H	CAPCOM Register 13	0000 _H
CC13IC	b FF92 _H	C9 _H	CAPCOM Register 13 Interrupt Control Register	0000 _H
CC14	FE9C _H	4E _H	CAPCOM Register 14	0000 _H
CC14IC	b FF94 _H	CA _H	CAPCOM Register 14 Interrupt Control Register	0000 _H
CC15	FE9E _H	4F _H	CAPCOM Register 15	0000 _H
CC15IC	b FF96 _H	CB _H	CAPCOM Register 15 Interrupt Control Register	0000 _H
CCM0	b FF52 _H	A9 _H	CAPCOM Mode Control Register 0	0000 _H
CCM1	b FF54 _H	AA _H	CAPCOM Mode Control Register 1	0000 _H
CCM2	b FF56 _H	AB _H	CAPCOM Mode Control Register 2	0000 _H
CCM3	b FF58 _H	AC _H	CAPCOM Mode Control Register 3	0000 _H
CP	FE10 _H	08 _H	CPU Context Pointer Register	FC00 _H
CRIC	b FF6A _H	B5 _H	GPT2 CAPREL Interrupt Control Register	0000 _H
CSP	FE08 _H	04 _H	CPU Code Segment Pointer Register (2 bits, read only)	0000 _H
DP0	b FF02 _H	81 _H	Port 0 Direction Control Register	0000 _H
DP1	b FF06 _H	83 _H	Port 1 Direction Control Register	0000 _H
DP2	b FFC2 _H	E1 _H	Port 2 Direction Control Register	0000 _H
DP3	b FFC6 _H	E3 _H	Port 3 Direction Control Register	0000 _H
DP4	b FF0A _H	85 _H	Port 4 Direction Control Register (2 bits)	00 _H

Special Function Registers Overview (cont'd)

Name	Physical Address	8-Bit Address	Description	Reset Value
S0RIC	b FF6E _H	B7 _H	Serial Channel 0 Receive Interrupt Control Register	0000 _H
S0TBUF	FEB0 _H	58 _H	Serial Channel 0 Transmit Buffer Register (write only)	00 _H
S0TIC	b FF6C _H	B6 _H	Serial Channel 0 Transmit Interrupt Control Register	0000 _H
S1BG	FEB3 _H	5E _H	Serial Channel 1 Baud Rate Generator Reload Register	0000 _H
S1CON	b FFB8 _H	DC _H	Serial Channel 1 Control Register	0000 _H
S1EIC	b FF76 _H	BB _H	Serial Channel 1 Error Interrupt Control Register	0000 _H
S1RBUF	FEBA _H	5D _H	Serial Channel 1 Receive Buffer Register (read only)	XX _H
S1RIC	b FF74 _H	BA _H	Serial Channel 1 Receive Interrupt Control Register	0000 _H
S1TBUF	FEB8 _H	5C _H	Serial Channel 1 Transmit Buffer Register (write only)	00 _H
S1TIC	b FF72 _H	B9 _H	Serial Channel 1 Transmit Interrupt Control Register	0000 _H
SP	FE12 _H	09 _H	CPU System Stack Pointer Register	FC00 _H
STKOV	FE14 _H	0A _H	CPU Stack Overflow Pointer Register	FA00 _H
STKUN	FE16 _H	0B _H	CPU Stack Underflow Pointer Register	FC00 _H
SYSCON	b FF0C _H	86 _H	CPU System Configuration Register	0xx0 _H *)
T0	FE50 _H	28 _H	CAPCOM Timer 0 Register	0000 _H
T01CON	b FF50 _H	A8 _H	CAPCOM Timer 0 and Timer 1 Control Register	0000 _H
T0IC	b FF9C _H	CE _H	CAPCOM Timer 0 Interrupt Control Register	0000 _H
T0REL	FE54 _H	2A _H	CAPCOM Timer 0 Reload Register	0000 _H
T1	FE52 _H	29 _H	CAPCOM Timer 1 Register	0000 _H
T1IC	b FF9E _H	CF _H	CAPCOM Timer 1 Interrupt Control Register	0000 _H
T1REL	FE56 _H	2B _H	CAPCOM Timer 1 Reload Register	0000 _H
T2	FE40 _H	20 _H	GPT1 Timer 2 Register	0000 _H
T2CON	b FF40 _H	A0 _H	GPT1 Timer 2 Control Register	0000 _H
T2IC	b FF60 _H	B0 _H	GPT1 Timer 2 Interrupt Control Register	0000 _H

Special Function Registers Overview (cont'd)

Name	Physical Address	8-Bit Address	Description	Reset Value
T3	FE42 _H	21 _H	GPT1 Timer 3 Register	0000 _H
T3CON	b FF42 _H	A1 _H	GPT1 Timer 3 Control Register	0000 _H
T3IC	b FF62 _H	B1 _H	GPT1 Timer 3 Interrupt Control Register	0000 _H
T4	FE44 _H	22 _H	GPT1 Timer 4 Register	0000 _H
T4CON	b FF44 _H	A2 _H	GPT1 Timer 4 Control Register	0000 _H
T4IC	b FF64 _H	B2 _H	GPT1 Timer 4 Interrupt Control Register	0000 _H
T5	FE46 _H	23 _H	GPT2 Timer 5 Register	0000 _H
T5CON	b FF46 _H	A3 _H	GPT2 Timer 5 Control Register	0000 _H
T5IC	b FF66 _H	B3 _H	GPT2 Timer 5 Interrupt Control Register	0000 _H
T6	FE48 _H	24 _H	GPT2 Timer 6 Register	0000 _H
T6CON	b FF48 _H	A4 _H	GPT2 Timer 6 Control Register	0000 _H
T6IC	b FF68 _H	B4 _H	GPT2 Timer 6 Interrupt Control Register	0000 _H
TFR	b FFAC _H	D6 _H	Trap Flag Register	0000 _H
WDT	FEAE _H	57 _H	Watchdog Timer Register (read only)	0000 _H
WDTCON	FFAE _H	D7 _H	Watchdog Timer Control Register	0000 _H
ZEROS	b FF1C _H	8E _H	Constant Value 0's Register (read only)	0000 _H

*) The system configuration is selected during reset.

Absolute Maximum Ratings

Ambient temperature under bias (T_A):	
SAB 83C166-5M, SAB 80C166-M	0 to + 70 °C
SAB 83C166-5M-T3, SAB 80C166-M-T3	- 40 to + 85 °C
Storage temperature (T_{ST})..... - 65 to + 150 °C	
Voltage on V_{CC} pins with respect to ground (V_{SS})	
Voltage on any pin with respect to ground (V_{SS})	- 0.5 to $V_{CC} + 0.5$ V
Input current on any pin during overload condition	
Absolute sum of all input currents during overload condition	100 mA
Power dissipation..... 1 W	

Note: Stresses above those listed under "Absolute Maximum Ratings" may cause permanent damage to the device. This is a stress rating only and functional operation of the device at these or any other conditions above those indicated in the operational sections of this specification is not implied. Exposure to absolute maximum rating conditions for extended periods may affect device reliability. During overload conditions ($V_{IN} > V_{CC}$ or $V_{IN} < V_{SS}$) the voltage on pins with respect to ground (V_{SS}) must not exceed the values defined by the Absolute Maximum Ratings.

Parameter Interpretation

The parameters listed in the following partly represent the characteristics of the SAB 80C166 and partly its demands on the system. To aid in interpreting the parameters right, when evaluating them for a design, they are marked in column "Symbol":

CC (Controller Characteristics):

The logic of the SAB 80C166 will provide signals with the respective timing characteristics.

SR (System Requirement):

The external system must provide signals with the respective timing characteristics to the SAB 80C166.

DC Characteristics

$V_{CC} = 5\text{ V} \pm 10\%$; $V_{SS} = 0\text{ V}$
 $T_A = 0\text{ to }+70\text{ }^\circ\text{C}$ for SAB 83C166-5M, SAB 80C166-M
 $T_A = -40\text{ to }+85\text{ }^\circ\text{C}$ for SAB 83C166-5M-T3, SAB 80C166-M-T3

Parameter	Symbol	Limit Values		Unit	Test Condition
		min.	max.		
Input low voltage	V_{IL} SR	-0.5	$0.2 V_{CC}$ -0.1	V	-
Input high voltage (all except \overline{RSTIN} and XTAL1)	V_{IH} SR	$0.2 V_{CC}$ + 0.9	$V_{CC} + 0.5$	V	-
Input high voltage \overline{RSTIN}	V_{IH1} SR	$0.6 V_{CC}$	$V_{CC} + 0.5$	V	-
Input high voltage XTAL1	V_{IH2} SR	$0.7 V_{CC}$	$V_{CC} + 0.5$	V	-
Output low voltage (Port 0, Port 1, Port 4, \overline{ALE} , \overline{RD} , \overline{WR} , \overline{BHE} , CLKOUT, \overline{RSTOUT})	V_{OL} CC	-	0.45	V	$I_{OL} = 2.4\text{ mA}$
Output low voltage (all other outputs)	V_{OL1} CC	-	0.45	V	$I_{OL1} = 1.6\text{ mA}$
Output high voltage (Port 0, Port 1, Port 4, \overline{ALE} , \overline{RD} , \overline{WR} , \overline{BHE} , CLKOUT, \overline{RSTOUT})	V_{OH} CC	$0.9 V_{CC}$ 2.4	-	V	$I_{OH} = -500\text{ }\mu\text{A}$ $I_{OH} = -2.4\text{ mA}$
Output high voltage (all other outputs)	V_{OH1} CC	$0.9 V_{CC}$ 2.4	-	V V	$I_{OH} = -250\text{ }\mu\text{A}$ $I_{OH} = -1.6\text{ mA}$
Input leakage current (Port 5) ¹⁾	I_{OZ1} CC	-	± 200	nA	$0\text{ V} < V_{IN} < V_{CC}$
Input leakage current (all other)	I_{OZ2} CC	-	± 500	nA	$0\text{ V} < V_{IN} < V_{CC}$
\overline{RSTIN} pullup resistor	R_{RST} CC	50	150	k Ω	-
Read inactive current ⁴⁾	I_{RH} ²⁾	-	-40	μA	$V_{OUT} = V_{OHmin}$
Read active current ⁴⁾	I_{RL} ³⁾	-500	-	μA	$V_{OUT} = V_{OLmax}$
\overline{ALE} inactive current ⁴⁾	I_{ALEL} ²⁾	-	150	μA	$V_{OUT} = V_{OLmax}$
\overline{ALE} active current ⁴⁾	I_{ALEH} ³⁾	2100	-	μA	$V_{OUT} = V_{OHmin}$
XTAL1 input current	I_{IL} CC	-	± 20	μA	$0\text{ V} < V_{IN} < V_{CC}$
Pin capacitance ⁵⁾ (digital inputs/outputs)	C_{IO} CC	-	10	pF	$f = 1\text{ MHz}$ $T_A = 25\text{ }^\circ\text{C}$
Power supply current	I_{CC}	-	$50 +$ $5 * f_{CPU}$	mA	Reset active f_{CPU} in [MHz] ⁶⁾
Idle mode supply current	I_{ID}	-	$30 +$ $1.5 * f_{CPU}$	mA	f_{CPU} in [MHz] ⁶⁾
Power-down mode supply current	I_{PD}	-	50	μA	$V_{CC} = 5.5\text{ V}$ ⁷⁾

Notes

- 1) This specification does not apply to the analog input (Port 5.x) which is currently converted.
- 2) The maximum current may be drawn while the respective signal line remains inactive.
- 3) The minimum current must be drawn in order to drive the respective signal line active.
- 4) This specification is only valid during Reset, or during Hold-mode.
- 5) Not 100% tested, guaranteed by design characterization.
- 6) The supply current is a function of the operating frequency. This dependency is illustrated in the figure below. These parameters are tested at V_{CCmax} and 20 MHz CPU clock with all outputs open.
- 7) All inputs (including pins configured as inputs) at 0 V to 0.1 V or at $V_{CC} - 0.1$ V to V_{CC} , $V_{REF} = 0$ V, all outputs (including pins configured as outputs) disconnected.
A voltage of $V_{CC} \geq 2.5$ V is sufficient to retain the content of the internal RAM during power down mode.

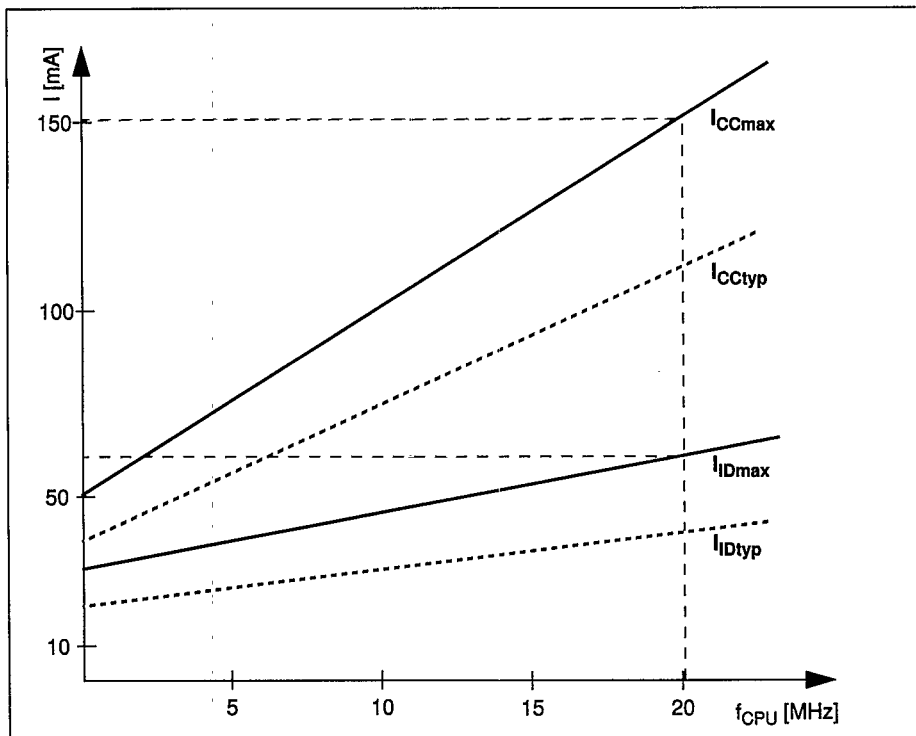

Figure 8
Supply/Idle Current as a Function of Operating Frequency

A/D Converter Characteristics

$V_{CC} = 5\text{ V} \pm 10\%$; $V_{SS} = 0\text{ V}$
 $T_A = 0\text{ to }+70\text{ }^\circ\text{C}$ for SAB 83C166-5M, SAB 80C166-M
 $T_A = -40\text{ to }+85\text{ }^\circ\text{C}$ for SAB 83C166-5M-T3, SAB 80C166-M-T3
 $4.0\text{ V} \leq V_{AREF} \leq V_{CC} + 0.1\text{ V}$; $V_{SS} - 0.1\text{ V} \leq V_{AGND} \leq V_{SS} + 0.2\text{ V}$

Parameter	Symbol	Limit Values		Unit	Test Condition
		min.	max.		
Analog input voltage range	V_{AIN} SR	V_{AGND}	V_{AREF}	V	1)
Sample time	t_S CC	–	$2 t_{SC}$		2) 4)
Conversion time	t_C CC	–	$10 t_{CC} + t_S + 4TCL$		3) 4)
Total unadjusted error	TUE CC	–	± 2	LSB	5)
Internal resistance of reference voltage source	R_{AREF} SR	–	$t_{CC} / 250 - 0.25$	$k\Omega$	t_{CC} in [ns] ^{6) 7)}
Internal resistance of analog source	R_{ASRC} SR	–	$t_S / 500 - 0.25$	$k\Omega$	t_S in [ns] ^{2) 7)}
ADC input capacitance	C_{AIN} CC	–	50	pF	7)

Notes

- 1) V_{AIN} may exceed V_{AGND} or V_{AREF} up to the absolute maximum ratings. However, the conversion result in these cases will be X000_H or X3FF_H, respectively.
- 2) During the sample time the input capacitance C_I can be charged/discharged by the external source. The internal resistance of the analog source must allow the capacitors to reach their final voltage level within t_S . After the end of the sample time t_S , changes of the analog input voltage have no effect on the conversion result. The value for the sample clock is $t_{SC} = TCL * 32$.
- 3) This parameter includes the sample time t_S , the time for determining the digital result and the time to load the result register with the conversion result. The value for the conversion clock is $t_{CC} = TCL * 32$.
- 4) This parameter depends on the ADC control logic. It is not a real maximum value, but rather a fixum.
- 5) TUE is tested at $V_{AREF} = 5.0\text{V}$, $V_{AGND} = 0\text{ V}$, $V_{CC} = 4.8\text{ V}$. It is guaranteed by design characterization for all other voltages within the defined voltage range.
- 6) During the conversion the ADC's capacitance must be repeatedly charged or discharged. The internal resistance of the reference voltage source must allow the capacitors to reach their respective voltage level within t_{CC} . The maximum internal resistance results from the CPU clock period.
- 7) Not 100% tested, guaranteed by design characterization.

Testing Waveforms

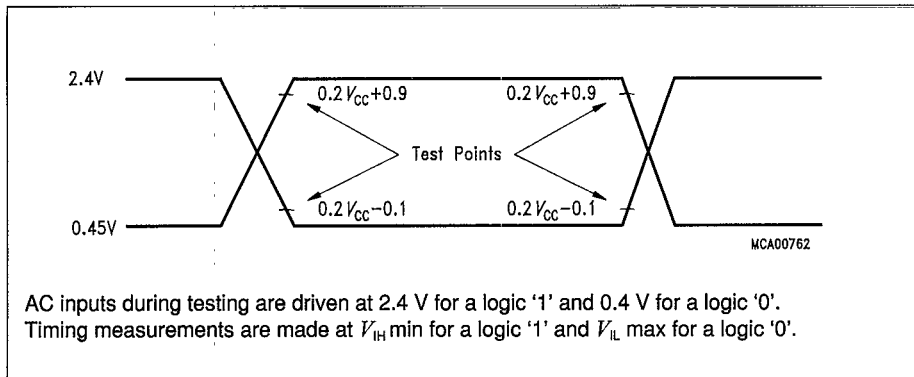

Figure 9
Input Output Waveforms

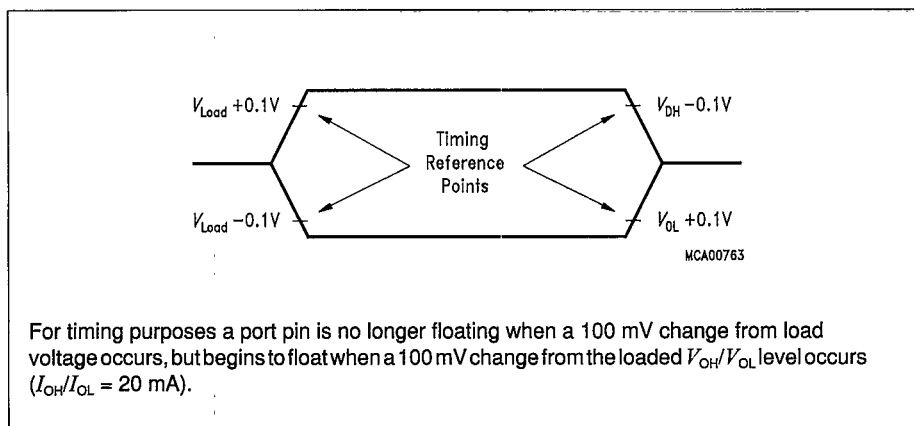

Figure 10
Float Waveforms

AC Characteristics

External Clock Drive XTAL1

$V_{CC} = 5\text{ V} \pm 10\%$; $V_{SS} = 0\text{ V}$

$T_A = 0\text{ to }+70\text{ }^\circ\text{C}$ for SAB 83C166-5M, SAB 80C166-M

$T_A = -40\text{ to }+85\text{ }^\circ\text{C}$ for SAB 83C166-5M-T3, SAB 80C166-M-T3

Parameter	Symbol	Max. CPU Clock = 20 MHz		Variable CPU Clock 1/2TCL = 1 to 20 MHz		Unit
		min.	max.	min.	max.	
Oscillator period	TCL SR	25	25	25	500	ns
High time	t_1 SR	6	—	6	—	ns
Low time	t_2 SR	6	—	6	—	ns
Rise time	t_3 SR	—	5	—	5	ns
Fall time	t_4 SR	—	5	—	5	ns

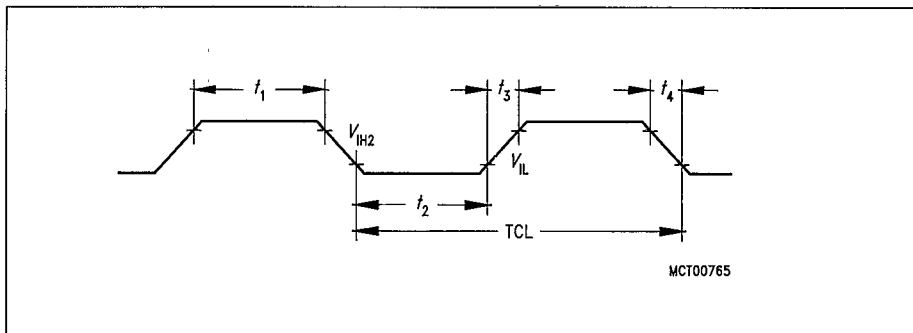

Figure 11
External Clock Drive XTAL1

Memory Cycle Variables

The timing tables below use three variables which are derived from registers SYSCON and BUSCON1 and represent the special characteristics of the programmed memory cycle. The following table describes, how these variables are to be computed.

Description	Symbol	Values
ALE Extension	t_A	$TCL * \langle ALECTL \rangle$
Memory Cycle Time Waitstates	t_C	$2TCL * (15 - \langle MCTC \rangle)$
Memory Tristate Time	t_F	$2TCL * (1 - \langle MTTC \rangle)$

AC Characteristics (cont'd)

Multiplexed Bus

$V_{CC} = 5\text{ V} \pm 10\%$; $V_{SS} = 0\text{ V}$

$T_A = 0\text{ to }+70\text{ }^\circ\text{C}$ for SAB 83C166-5M, SAB 80C166-M

$T_A = -40\text{ to }+85\text{ }^\circ\text{C}$ for SAB 83C166-5M-T3, SAB 80C166-M-T3

C_L (for Port 0, Port 1, Port 4, ALE, $\overline{\text{RD}}$, $\overline{\text{WR}}$, $\overline{\text{BHE}}$, CLKOUT) = 100 pF

ALE cycle time = $6\text{ TCL} + 2t_A + t_C + t_F$ (150 ns at 20-MHz CPU clock without waitstates)

Parameter	Symbol	CC	Max. CPU Clock = 20 MHz		Variable CPU Clock 1/2TCL = 1 to 20 MHz		Unit
			min.	max.	min.	max.	
ALE high time	t_5	CC	$15 + t_A$	—	$\text{TCL} - 10 + t_A$	—	ns
Address setup to ALE	t_6	CC	$10 + t_A$	—	$\text{TCL} - 15 + t_A$	—	ns
Address hold after ALE	t_7	CC	$15 + t_A$	—	$\text{TCL} - 10 + t_A$	—	ns
ALE falling edge to $\overline{\text{RD}}$, $\overline{\text{WR}}$ (with RW-delay)	t_8	CC	$15 + t_A$	—	$\text{TCL} - 10 + t_A$	—	ns
ALE falling edge to $\overline{\text{RD}}$, $\overline{\text{WR}}$ (no RW-delay)	t_9	CC	$-10 + t_A$	—	$-10 + t_A$	—	ns
Address float after $\overline{\text{RD}}$, $\overline{\text{WR}}$ (with RW-delay)	t_{10}	CC	—	5	—	5	ns
Address float after $\overline{\text{RD}}$, $\overline{\text{WR}}$ (no RW-delay)	t_{11}	CC	—	30	—	$\text{TCL} + 5$	ns
$\overline{\text{RD}}$, $\overline{\text{WR}}$ low time (with RW-delay)	t_{12}	CC	$40 + t_C$	—	$2\text{TCL} - 10$ $+ t_C$	—	ns
$\overline{\text{RD}}$, $\overline{\text{WR}}$ low time (no RW-delay)	t_{13}	CC	$65 + t_C$	—	$3\text{TCL} - 10$ $+ t_C$	—	ns
$\overline{\text{RD}}$ to valid data in (with RW-delay)	t_{14}	SR	—	$30 + t_C$	—	$2\text{TCL} - 20$ $+ t_C$	ns
$\overline{\text{RD}}$ to valid data in (no RW-delay)	t_{15}	SR	—	$55 + t_C$	—	$3\text{TCL} - 20$ $+ t_C$	ns
ALE low to valid data in	t_{16}	SR	—	55 $+ t_A + t_C$	—	$3\text{TCL} - 20$ $+ t_A + t_C$	ns
Address to valid data in	t_{17}	SR	—	75 $+ 2t_A + t_C$	—	$4\text{TCL} - 25$ $+ 2t_A + t_C$	ns
Data hold after $\overline{\text{RD}}$ rising edge	t_{18}	SR	0	—	0	—	ns
Data float after $\overline{\text{RD}}$	t_{19}	SR	—	$35 + t_F$	—	$2\text{TCL} - 15$ $+ t_F$	ns
Data valid to $\overline{\text{WR}}$	t_{22}	CC	$35 + t_C$	—	$2\text{TCL} - 15$ $+ t_C$	—	ns

Parameter	Symbol	Max. CPU Clock = 20 MHz		Variable CPU Clock 1/2TCL = 1 to 20 MHz		Unit
		min.	max.	min.	max.	
Data hold after \overline{WR}	t_{23} CC	$35 + t_F$	—	$2TCL - 15 + t_F$	—	ns
ALE rising edge after \overline{RD} , \overline{WR}	t_{25} CC	$35 + t_F$	—	$2TCL - 15 + t_F$	—	ns
Address hold after \overline{RD} , \overline{WR}	t_{27} CC	$35 + t_F$	—	$2TCL - 15 + t_F$	—	ns

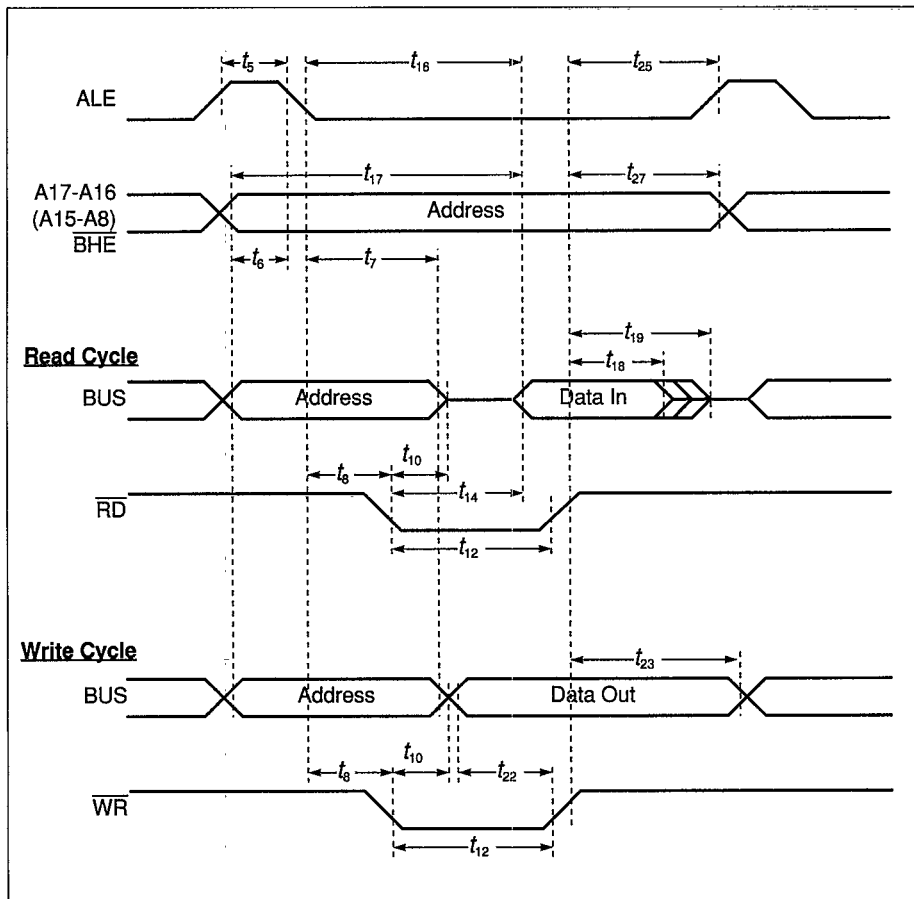

Figure 12-1
External Memory Cycle: Multiplexed Bus, With Read/Write Delay, Normal ALE

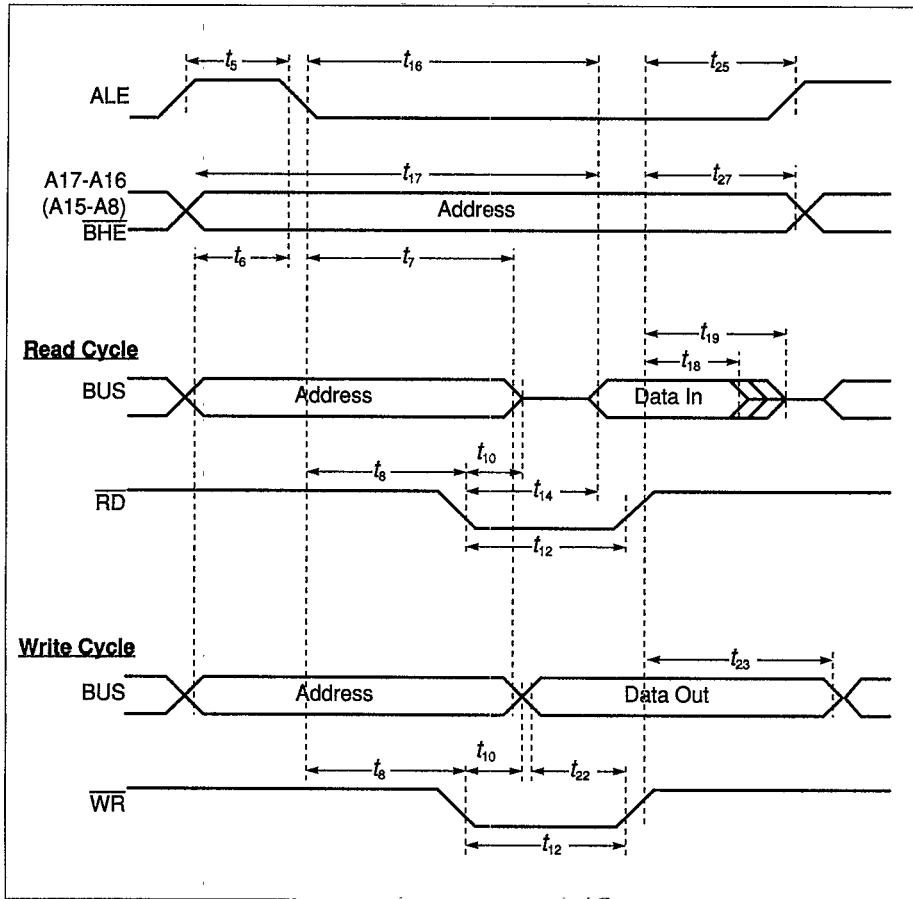

Figure 12-2
External Memory Cycle: Multiplexed Bus, With Read/Write Delay, Extended ALE

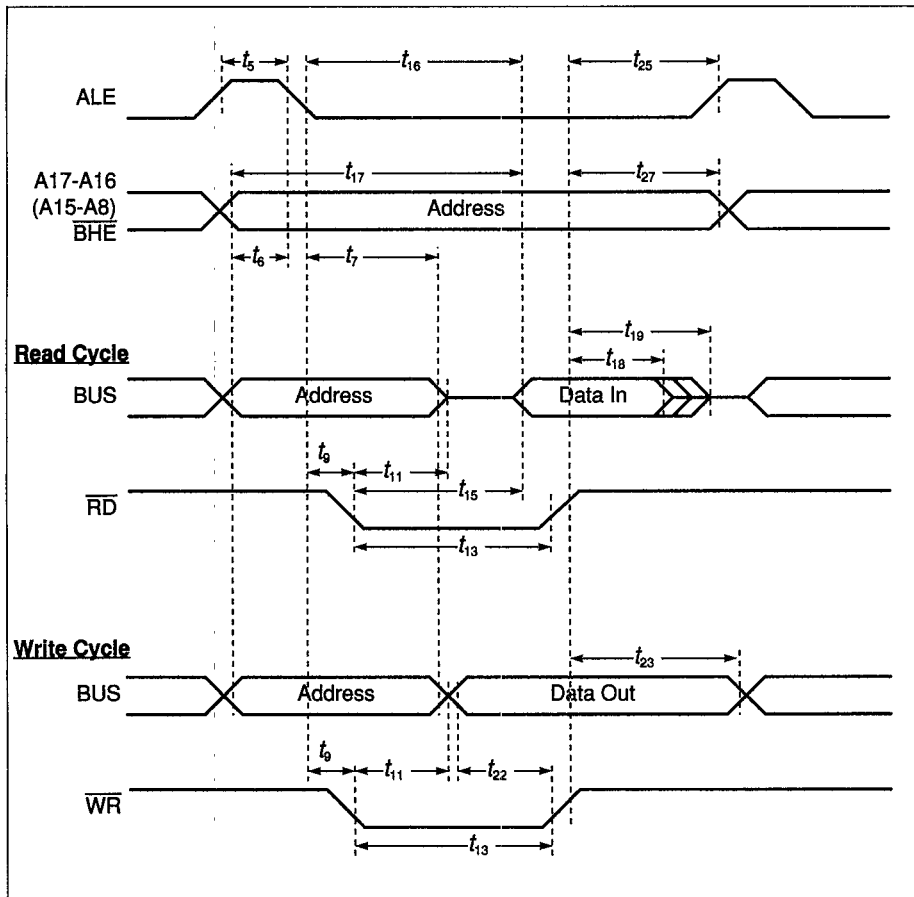

Figure 12-3
External Memory Cycle: Multiplexed Bus, No Read/Write Delay, Normal ALE

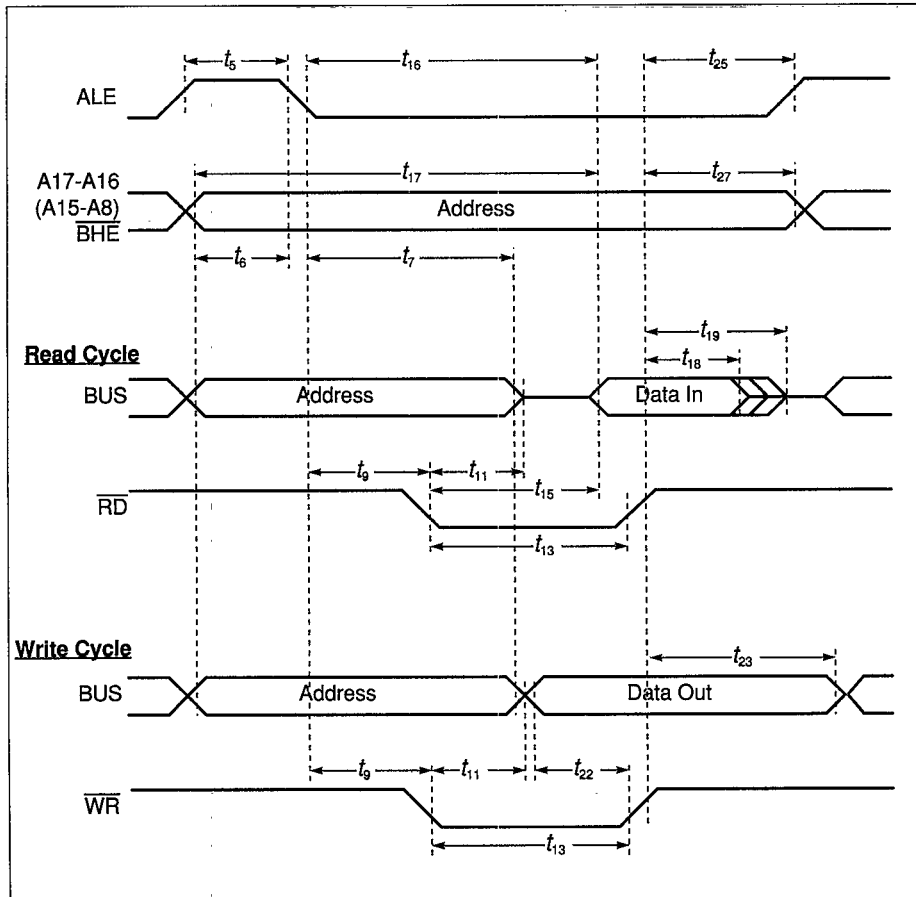

Figure 12-4
External Memory Cycle: Multiplexed Bus, No Read/Write Delay, Extended ALE

AC Characteristics (cont'd)**Demultiplexed Bus** $V_{CC} = 5 V \pm 10\%$; $V_{SS} = 0 V$ $T_A = 0$ to $+70\text{ }^\circ\text{C}$ for SAB 83C166-5M, SAB 80C166-M $T_A = -40$ to $+85\text{ }^\circ\text{C}$ for SAB 83C166-5M-T3, SAB 80C166-M-T3 C_L (for Port 0, Port 1, Port 4, ALE, RD, WR, BHE, CLKOUT) = 100 pFALE cycle time = $4 \text{ TCL} + 2t_A + t_C + t_F$ (100 ns at 20-MHz CPU clock without waitstates)

Parameter	Symbol		Max. CPU Clock = 20 MHz		Variable CPU Clock 1/2TCL = 1 to 20 MHz		Unit
			min.	max.	min.	max.	
ALE high time	t_5	CC	$15 + t_A$	–	$\text{TCL} - 10 + t_A$	–	ns
Address setup to ALE	t_6	CC	$10 + t_A$	–	$\text{TCL} - 15 + t_A$	–	ns
ALE falling edge to $\overline{\text{RD}}$, WR (with RW-delay)	t_8	CC	$15 + t_A$	–	$\text{TCL} - 10$ $+ t_A$	–	ns
ALE falling edge to $\overline{\text{RD}}$, WR (no RW-delay)	t_9	CC	$-10 + t_A$	–	-10 $+ t_A$	–	ns
$\overline{\text{RD}}$, WR low time (with RW-delay)	t_{12}	CC	$40 + t_C$	–	$2\text{TCL} - 10$ $+ t_C$	–	ns
$\overline{\text{RD}}$, WR low time (no RW-delay)	t_{13}	CC	$65 + t_C$	–	$3\text{TCL} - 10$ $+ t_C$	–	ns
$\overline{\text{RD}}$ to valid data in (with RW-delay)	t_{14}	SR	–	$30 + t_C$	–	$2\text{TCL} - 20$ $+ t_C$	ns
$\overline{\text{RD}}$ to valid data in (no RW-delay)	t_{15}	SR	–	$55 + t_C$	–	$3\text{TCL} - 20$ $+ t_C$	ns
ALE low to valid data in	t_{16}	SR	–	55 $+ t_A + t_C$	–	$3\text{TCL} - 20$ $+ t_A + t_C$	ns
Address to valid data in	t_{17}	SR	–	75 $+ 2t_A + t_C$	–	$4\text{TCL} - 25$ $+ 2t_A + t_C$	ns
Data hold after $\overline{\text{RD}}$ rising edge	t_{18}	SR	0	–	0	–	ns
Data float after $\overline{\text{RD}}$ rising edge (with RW-delay)	t_{20}	SR	–	$35 + t_F$	–	$2\text{TCL} - 15$ $+ t_F$	ns
Data float after $\overline{\text{RD}}$ rising edge (no RW-delay)	t_{21}	SR	–	$15 + t_F$	–	$\text{TCL} - 10$ $+ t_F$	ns
Data valid to $\overline{\text{WR}}$	t_{22}	CC	$35 + t_C$	–	$2\text{TCL} - 15$ $+ t_C$	–	ns
Data hold after $\overline{\text{WR}}$	t_{24}	CC	$15 + t_F$	–	$\text{TCL} - 10 + t_F$	–	ns

Parameter	Symbol	Max. CPU Clock = 20 MHz		Variable CPU Clock 1/2TCL = 1 to 20 MHz		Unit
		min.	max.	min.	max.	
ALE rising edge after \overline{RD} , \overline{WR}	t_{26} CC	$-10 + t_F$	—	$-10 + t_F$	—	ns
Address hold after \overline{RD} , \overline{WR}	t_{28} CC	$0 + t_F$	—	$0 + t_F$	—	ns

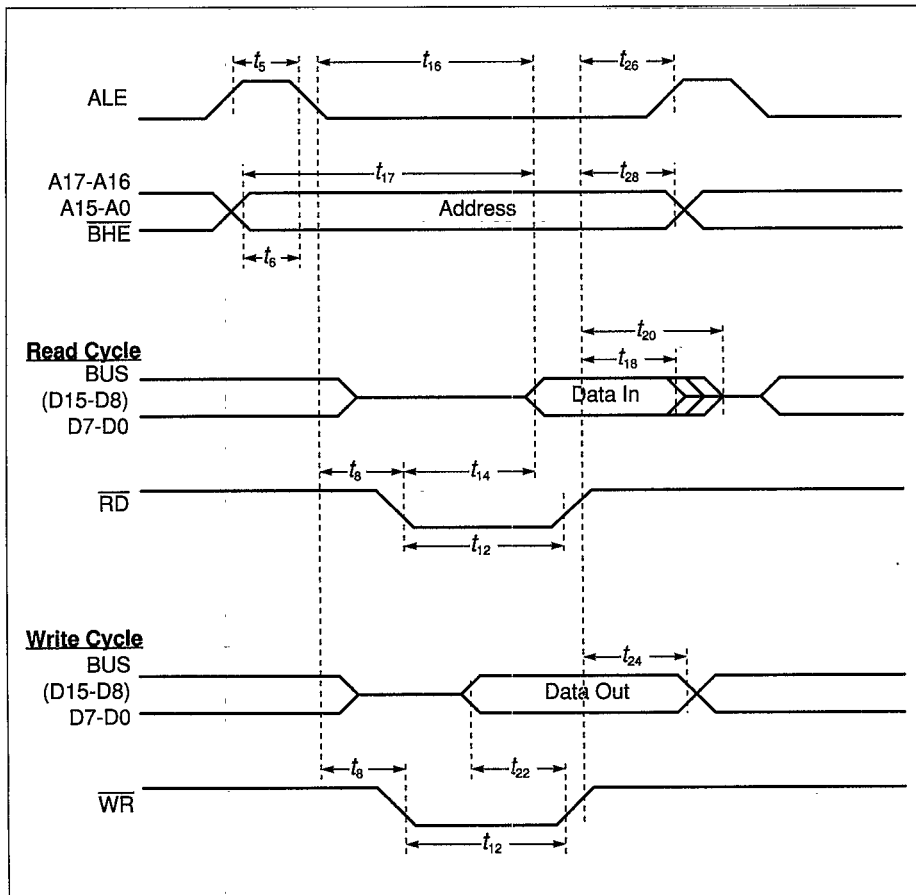

Figure 13-1
External Memory Cycle: Demultiplexed Bus, With Read/Write Delay, Normal ALE

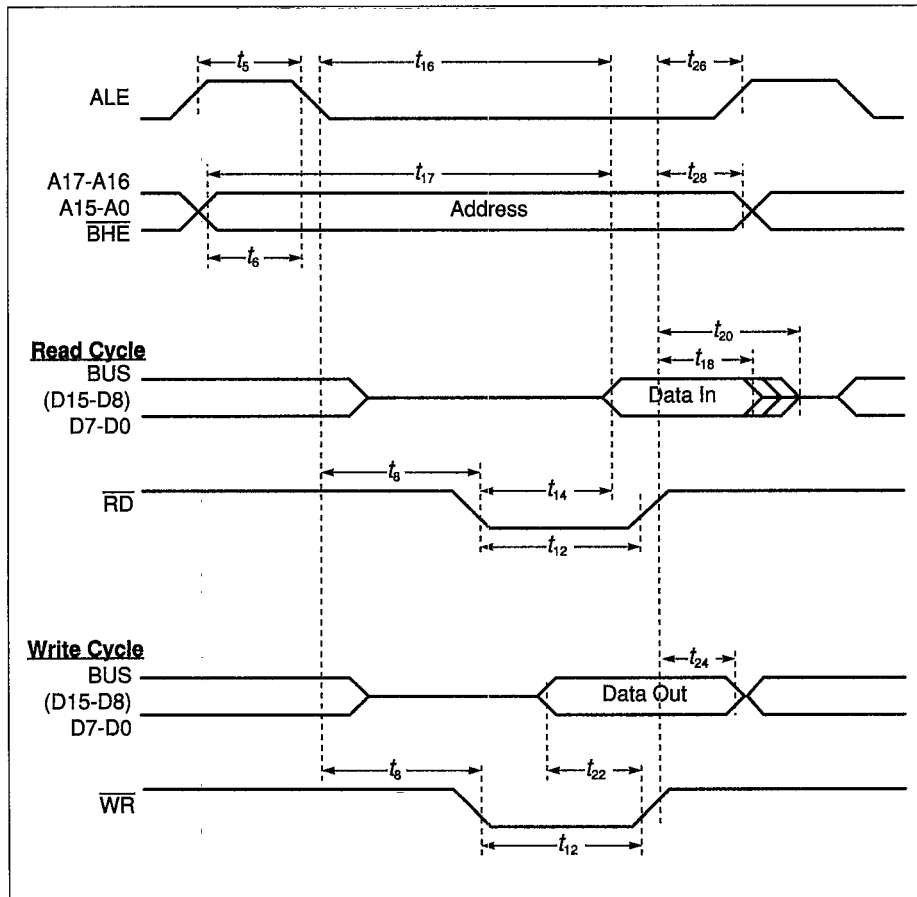

Figure 13-2
External Memory Cycle: Demultiplexed Bus, With Read/Write Delay, Extended ALE

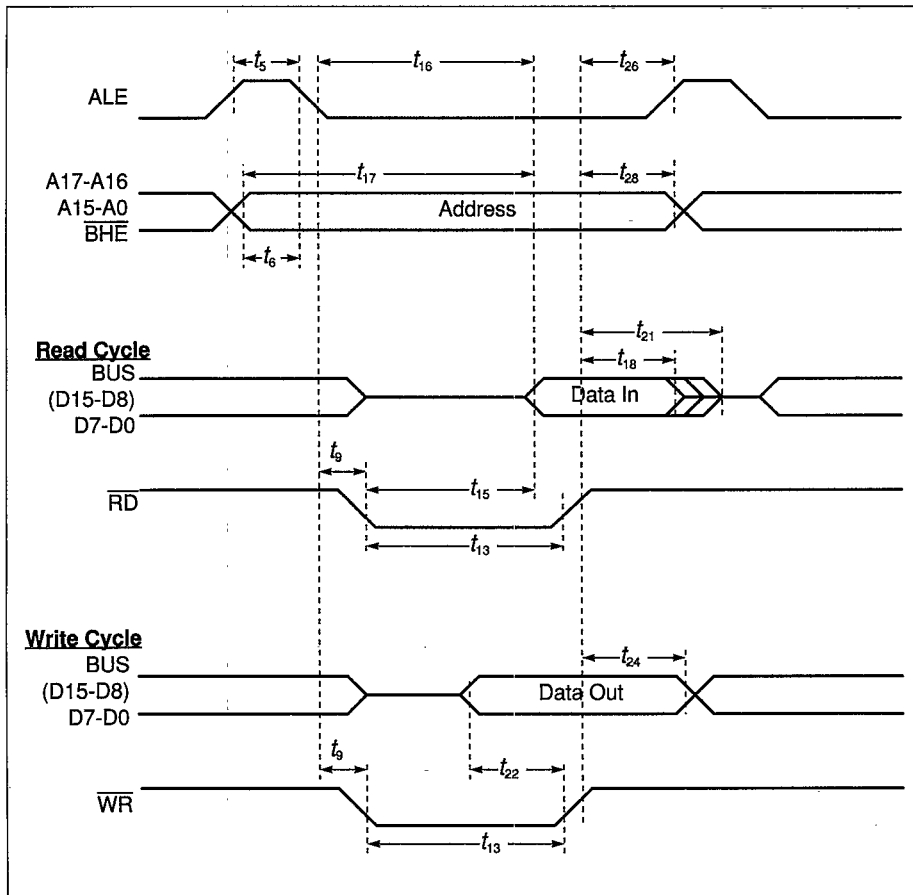

Figure 13-3
External Memory Cycle: Demultiplexed Bus, No Read/Write Delay, Normal ALE

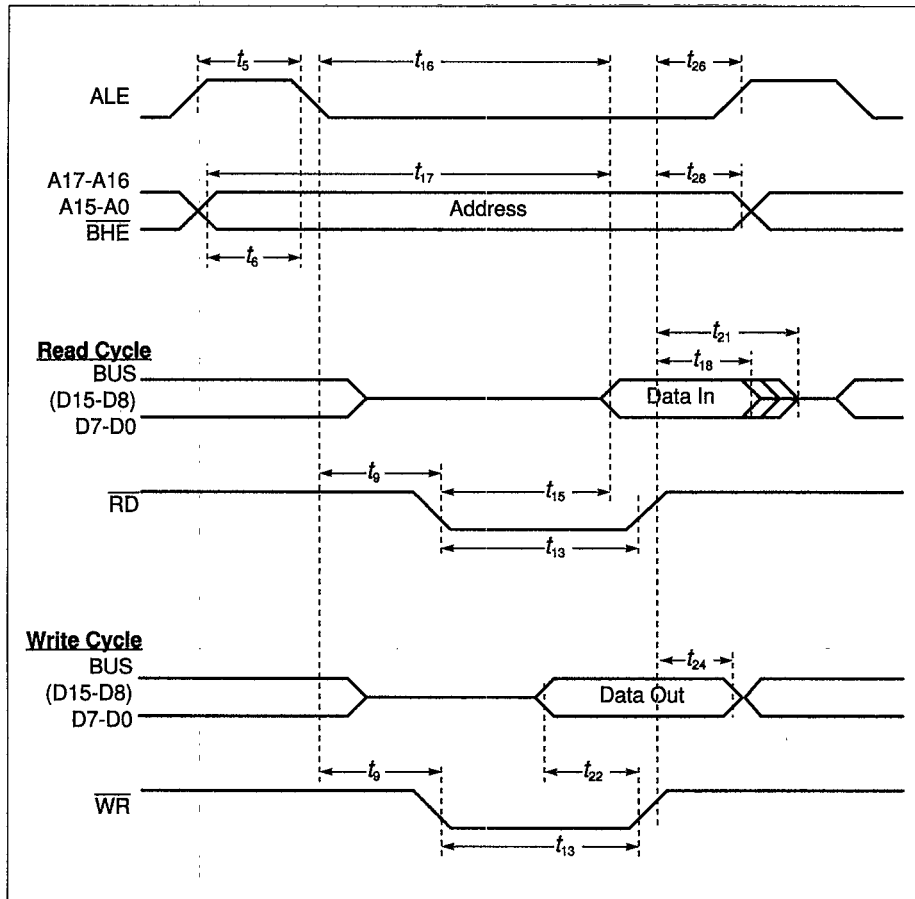

Figure 13-4
External Memory Cycle: Demultiplexed Bus, No Read/Write Delay, Extended ALE

AC Characteristics (cont'd)

CLKOUT and $\overline{\text{READY}}$

$V_{CC} = 5\text{ V} \pm 10\%$; $V_{SS} = 0\text{ V}$
 $T_A = 0\text{ to }+70\text{ }^\circ\text{C}$ for SAB 83C166-5M, SAB 80C166-M
 $T_A = -40\text{ to }+85\text{ }^\circ\text{C}$ for SAB 83C166-5M-T3, SAB 80C166-M-T3
 C_L (for Port 0, Port 1, Port 4, ALE, $\overline{\text{RD}}$, $\overline{\text{WR}}$, $\overline{\text{BHE}}$, CLKOUT) = 100 pF

Parameter	Symbol	Max. CPU Clock = 20 MHz		Variable CPU Clock 1/2TCL = 1 to 20 MHz		Unit
		min.	max.	min.	max.	
CLKOUT cycle time	t_{29} CC	50	50	2TCL	2TCL	ns
CLKOUT high time	t_{30} CC	20	–	TCL – 5	–	ns
CLKOUT low time	t_{31} CC	15	–	TCL – 10	–	ns
CLKOUT rise time	t_{32} CC	–	5	–	5	ns
CLKOUT fall time	t_{33} CC	–	5	–	5	ns
CLKOUT rising edge to ALE falling edge	t_{34} CC	$0 + t_A$	$10 + t_A$	$0 + t_A$	$10 + t_A$	ns
Synchronous $\overline{\text{READY}}$ setup time to CLKOUT	t_{35} SR	10	–	10	–	ns
Synchronous $\overline{\text{READY}}$ hold time after CLKOUT	t_{36} SR	10	–	10	–	ns
Asynchronous $\overline{\text{READY}}$ low time	t_{37} SR	65	–	2TCL + 15	–	ns
Asynchronous $\overline{\text{READY}}$ setup time ¹⁾	t_{58} SR	20	–	20	–	ns
Asynchronous $\overline{\text{READY}}$ hold time ¹⁾	t_{59} SR	0	–	0	–	ns
Async. $\overline{\text{READY}}$ hold time after $\overline{\text{RD}}$, $\overline{\text{WR}}$ high (Demultiplexed Bus) ²⁾	t_{60} SR	0	$0 + 2t_A + t_F$ ²⁾	0	TCL - 25 $+ 2t_A + t_F$ ²⁾	ns

Notes

- 1) These timings are given for test purposes only, in order to assure recognition at a specific clock edge.
- 2) Demultiplexed bus is the worst case. For multiplexed bus 2TCL are to be added to the maximum values. This adds even more time for deactivating $\overline{\text{READY}}$.

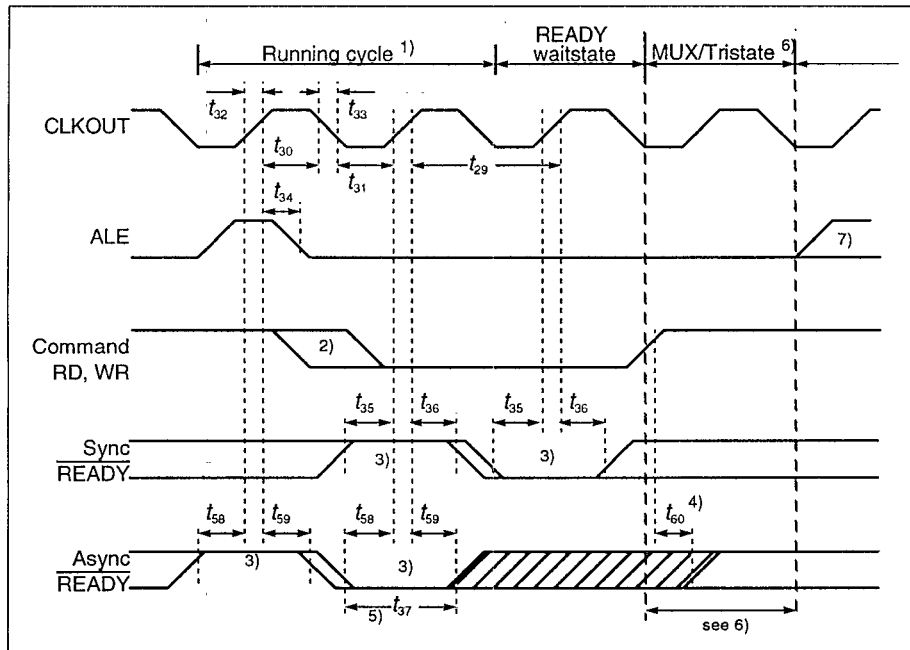

Figure 14
CLKOUT and $\overline{\text{READY}}$

Notes

- 1) Cycle as programmed, including MCTC waitstates (Example shows 0 MCTC WS).
- 2) The leading edge of the respective command depends on RW-delay.
- 3) $\overline{\text{READY}}$ sampled HIGH at this sampling point generates a $\overline{\text{READY}}$ controlled waitstate, $\overline{\text{READY}}$ sampled LOW at this sampling point terminates the currently running bus cycle.
- 4) $\overline{\text{READY}}$ may be deactivated in response to the trailing (rising) edge of the corresponding command ($\overline{\text{RD}}$ or $\overline{\text{WR}}$).
- 5) If the Asynchronous $\overline{\text{READY}}$ signal does not fulfill the indicated setup and hold times with respect to CLKOUT (e.g. because CLKOUT is not enabled), it must fulfill t_{37} in order to be safely synchronized. This is guaranteed, if $\overline{\text{READY}}$ is removed in response to the command (see Note 4)).
- 6) Multiplexed bus modes have a MUX waitstate added after a bus cycle, and an additional MTTC waitstate may be inserted here.
For a multiplexed bus with MTTC waitstate this delay is 2 CLKOUT cycles, for a demultiplexed bus without MTTC waitstate this delay is zero.
- 7) The next external bus cycle may start here.

AC Characteristics (cont'd)
External Bus Arbitration

$V_{CC} = 5\text{ V} \pm 10\%$; $V_{SS} = 0\text{ V}$
 $T_A = 0\text{ to }+70\text{ }^\circ\text{C}$ for SAB 83C166-5M, SAB 80C166-M
 $T_A = -40\text{ to }+85\text{ }^\circ\text{C}$ for SAB 83C166-5M-T3, SAB 80C166-M-T3
 C_L (for Port 0, Port 1, Port 4, ALE, $\overline{\text{RD}}$, $\overline{\text{WR}}$, $\overline{\text{BHE}}$, CLKOUT) = 100 pF

Parameter	Symbol	Max. CPU Clock = 20 MHz		Variable CPU Clock 1/2TCL = 1 to 20 MHz		Unit
		min.	max.	min.	max.	
HOLD input setup time to CLKOUT	t_{61} SR	20	—	20	—	ns
CLKOUT to $\overline{\text{HLDA}}$ high or $\overline{\text{BREQ}}$ low delay	t_{62} CC	—	50	—	50	ns
CLKOUT to $\overline{\text{HLDA}}$ low or $\overline{\text{BREQ}}$ high delay	t_{63} CC	—	50	—	50	ns
Other signals release	t_{66} CC	—	25	—	25	ns
Other signals drive	t_{67} CC	-5	35	-5	35	ns

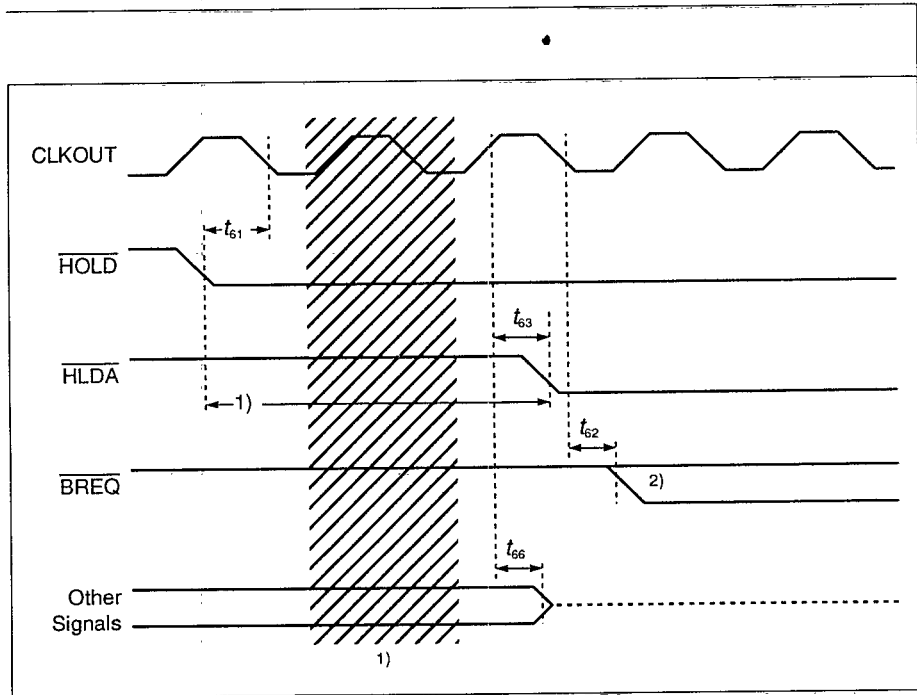

Figure 15
External Bus Arbitration, Releasing the Bus

Notes

- 1) The SAB 80C166 will complete the currently running bus cycle before granting bus access.
- 2) This is the first possibility for $\overline{\text{BREQ}}$ to get active.

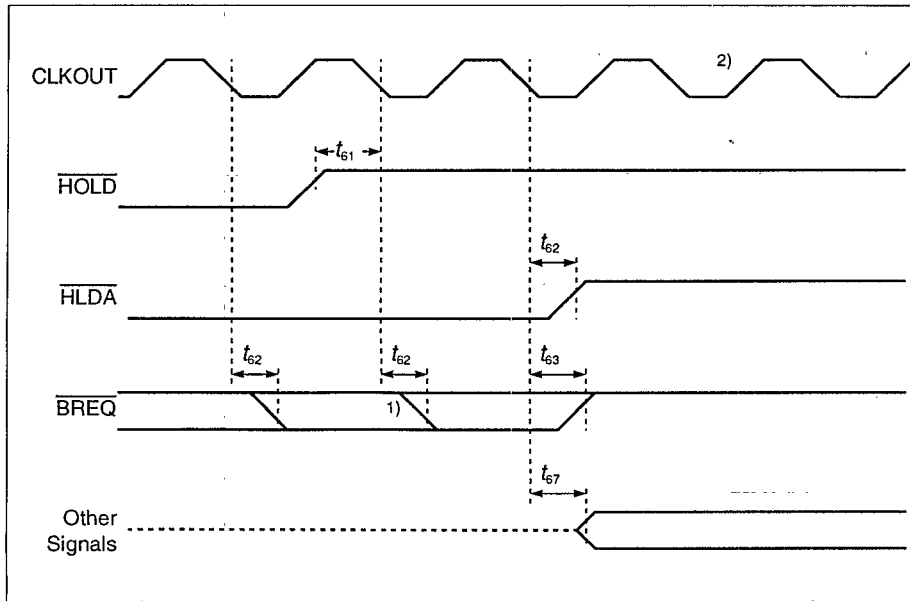

Figure 16
External Bus Arbitration, (Regaining the Bus)

Notes

- 1) This is the last chance for $\overline{\text{BREQ}}$ to trigger the indicated regain-sequence. Even if $\overline{\text{BREQ}}$ is activated earlier, the regain-sequence is initiated by HOLD going high. Please note that HOLD may also be deactivated without the SAB 80C166 requesting the bus.
- 2) The next SAB 80C166 driven bus cycle may start here.