

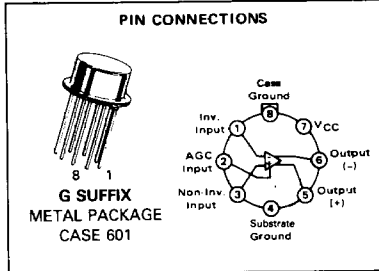
**MC1590G**

**WIDEBAND AMPLIFIER WITH AGC**  
**SILICON MONOLITHIC INTEGRATED CIRCUIT**

**RF/IF/AUDIO AMPLIFIER**

... an integrated circuit featuring wide-range AGC for use in RF/IF amplifiers and audio amplifiers over the temperature range, -55 to +125°C.

- High Power Gain — 50 dB Typ at 10 MHz  
 45 dB Typ at 60 MHz  
 35 dB Typ at 100 MHz
- Wide-Range AGC — 60 dB min, dc to 60 MHz
- Low Reverse Transfer Admittance — <10 μmhos Typ at 60 MHz
- 6.0 to 15-Volt Operation, Single-Polarity Power Supply



**MAXIMUM RATINGS (T<sub>A</sub> = +25°C unless otherwise noted)**

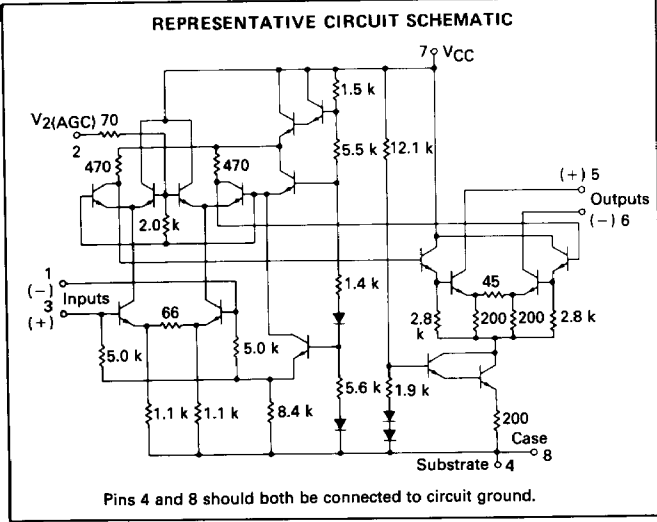
Rating	Symbol*	Value	Unit
Power Supply Voltage	V <sub>CC</sub>	+18	Vdc
Output Supply	V <sub>O</sub>	+18	Vdc
AGC Supply	V <sub>2</sub> (AGC)	V <sub>CC</sub>	Vdc
Differential Input Voltage	V <sub>I</sub>	5.0	Vdc
Operating Temperature Range	T <sub>A</sub>	-55 to +125	°C
Storage Temperature Range	T <sub>stg</sub>	-65 to +150	°C
Junction Temperature	T <sub>J</sub>	+175	°C

**ADMITTANCE PARAMETERS (V<sub>CC</sub> = +12 Vdc, T<sub>A</sub> = +25°C)**

Parameter	Symbol	f = MHz Typ		Unit
		30	60	
Single-Ended Input Admittance	g <sub>11</sub>	0.4	0.6	mmhos
	b <sub>11</sub>	1.2	-3.0	
Single-Ended Output Admittance	g <sub>22</sub>	0.05	0.1	mmhos
	b <sub>22</sub>	0.5	1.0	
Forward Transfer Admittance (Pin 1 to Pin 5)	Y <sub>21</sub>	175	150	mmhos
	θ <sub>21</sub> (Polar)	-30	-105	
Reverse Transfer Admittance*	g <sub>12</sub>	-0	-0	μmhos
	b <sub>12</sub>	-5.0	-10	

\*The value of Reverse Transfer Admittance includes the feedback admittance of the test circuit used in the measurement. The total feedback capacitance (including test circuit) is 0.025 pF and is a more practical value for design calculations than the internal feedback of the device alone. (See Figure 10.)

**REPRESENTATIVE CIRCUIT SCHEMATIC**



**SCATTERING PARAMETERS (V<sub>CC</sub> = +12 Vdc, T<sub>A</sub> = +25°C, Z<sub>0</sub> = 50 Ω)**

Parameter	Symbol	f = MHz Typ		Unit
		30	60	
Input Reflection Coefficient	S <sub>11</sub>	0.95	0.93	—
	θ <sub>11</sub>	-7.3	-16	
Output Reflection Coefficient	S <sub>22</sub>	0.99	0.98	—
	θ <sub>22</sub>	-3.0	-5.5	
Forward Transmission Coefficient	S <sub>21</sub>	16.8	14.7	—
	θ <sub>21</sub>	128	64.3	
Reverse Transmission Coefficient	S <sub>12</sub>	0.00048	0.00092	—
	θ <sub>12</sub>	84.9	79.2	

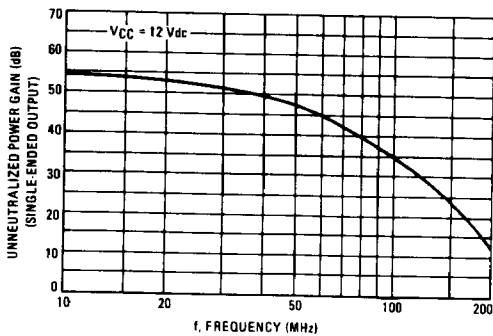
# MC1590G

**ELECTRICAL CHARACTERISTICS** ( $V_{CC} = +12$  Vdc,  $f = 60$  MHz, BW = 1.0 MHz,  $T_A = -55^\circ\text{C}$  to  $+125^\circ\text{C}$  unless otherwise noted)

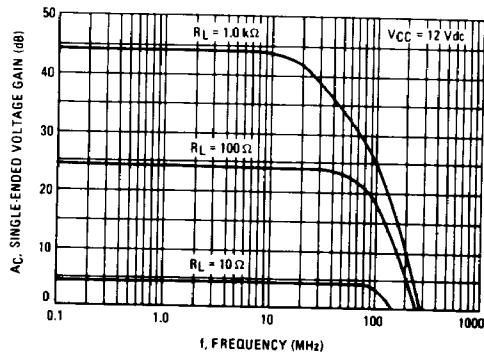
Characteristic	Fig.	Symbol	Min	Typ	Max	Unit
AGC Range ( $V_2(\text{AGC}) = 5.0$ V to $7.0$ V) ( $V_2(\text{AGC}) = 5.0$ V to $7.0$ V, $T_A = 25^\circ\text{C}$ )	24	$M_{\text{AGC}}$	58 60	— 88	— —	dB
Single-Ended Power Gain  ( $T_A = 25^\circ\text{C}$ )	24	$G_p$	37 40	— 45	— —	dB
Noise Figure ( $R_S$ optimized for best NF) ( $T_A = 25^\circ\text{C}$ )	24	NF	—	6.0	7.0	dB
Output Stage Current (Sum of Pins 5 and 6)  ( $T_A = 25^\circ\text{C}$ )	32	$I_O$	3.5 4.0	— 5.6	8.0 7.5	mA
Output Current Matching (Magnitude of Difference of Output Currents) ( $I_5 - I_6$ ) ( $T_A = 25^\circ\text{C}$ )	32	$\Delta I_O$	—	0.7	—	mA
Power Supply Current ( $V_O = 0$ V) ( $V_O = 0$ V, $T_A = 25^\circ\text{C}$ )	32	$I_{CC}$	— —	— 14	20 17	mA
Power Consumption ( $12 \times I_{CC}$ ) ( $V_I = 0$ V) ( $V_I = 0$ V, $T_A = 25^\circ\text{C}$ )	—	$P_C$	— —	— 168	240 204	mW

2

**FIGURE 1 – UNNEUTRALIZED POWER GAIN versus FREQUENCY**  
(Tuned Amplifier, See Figure 24)



**FIGURE 2 – VOLTAGE GAIN versus FREQUENCY**  
(Video Amplifier, See Figure 26)

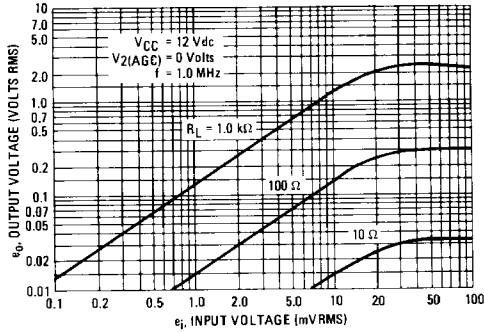


# MC1590G

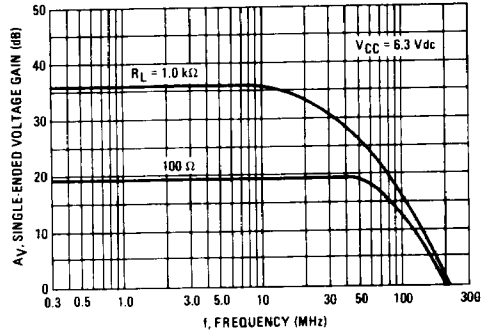
## TYPICAL CHARACTERISTICS

( $V_2(AGC) = 0$ ,  $V_{CC} = 12$  Vdc,  $T_A = +25^\circ\text{C}$  unless otherwise noted)

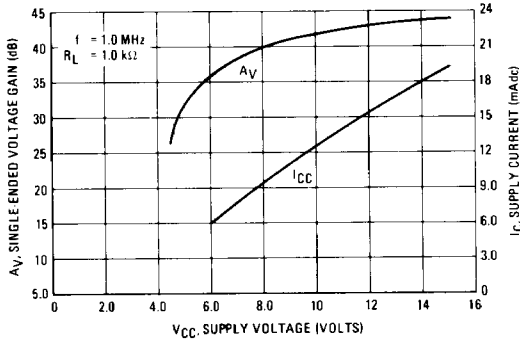
**FIGURE 3 – DYNAMIC RANGE: OUTPUT VOLTAGE versus INPUT VOLTAGE (Video Amplifier, See Figure 26)**



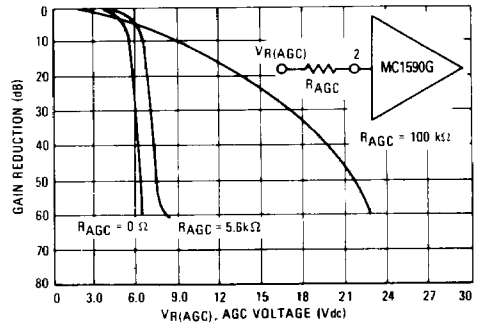
**FIGURE 4 – VOLTAGE GAIN versus FREQUENCY (Video Amplifier, See Figure 26)**



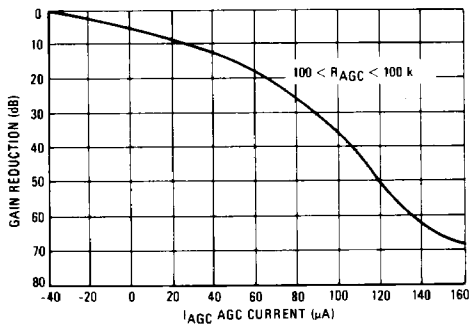
**FIGURE 5 – VOLTAGE GAIN AND SUPPLY CURRENT versus SUPPLY VOLTAGE (Video Amplifier, See Figure 26)**



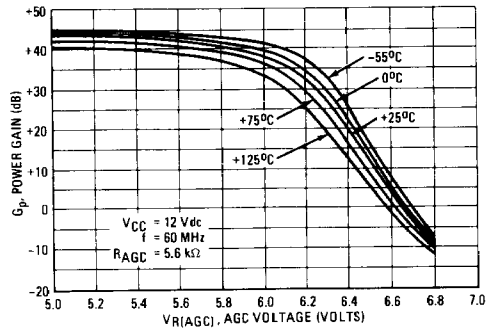
**FIGURE 6 – TYPICAL GAIN REDUCTION versus AGC VOLTAGE**



**FIGURE 7 – TYPICAL GAIN REDUCTION versus AGC CURRENT**



**FIGURE 8 – FIXED TUNED POWER GAIN REDUCTION versus TEMPERATURE (See Test Circuit, Figure 24)**



TYPICAL CHARACTERISTICS (continued)

FIGURE 9 – POWER GAIN versus SUPPLY VOLTAGE  
(See Test Circuit, Figure 24)

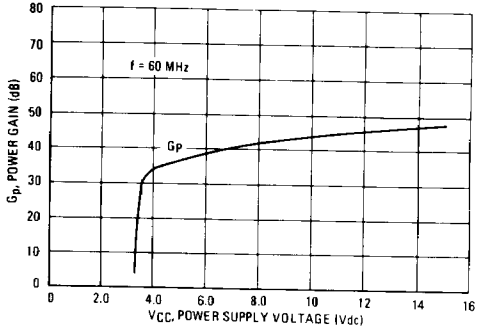


FIGURE 10 – REVERSE TRANSFER ADMITTANCE versus FREQUENCY  
(See Parameter Table, Page 1)

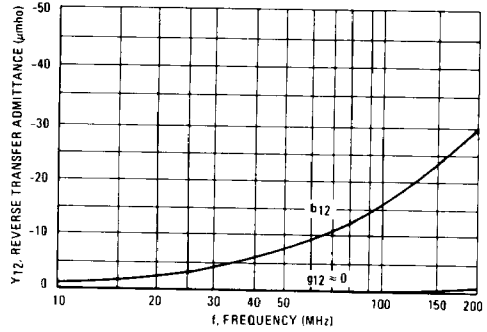


FIGURE 11 – NOISE FIGURE versus FREQUENCY

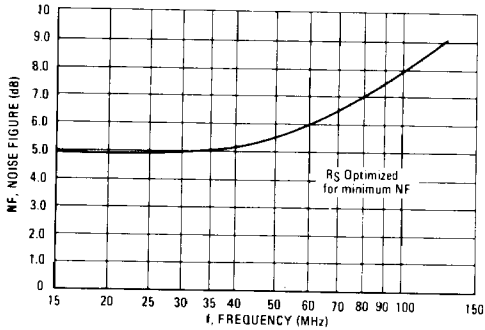


FIGURE 12 – NOISE FIGURE versus SOURCE RESISTANCE

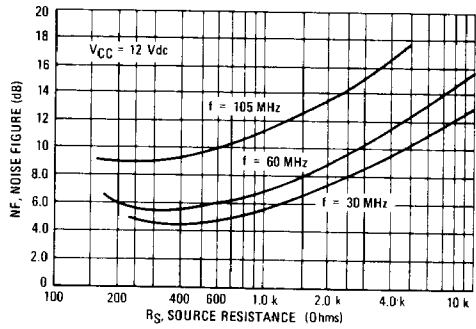
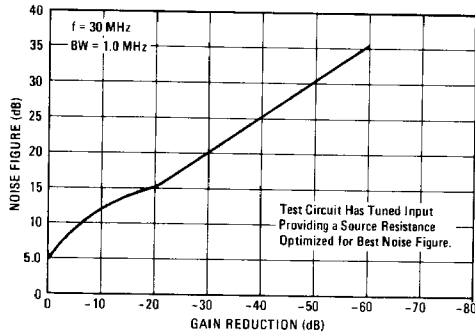


FIGURE 13 – NOISE FIGURE versus AGC GAIN REDUCTION



# MC1590G

## TYPICAL CHARACTERISTICS (continued)

FIGURE 14 — SINGLE-ENDED OUTPUT ADMITTANCE

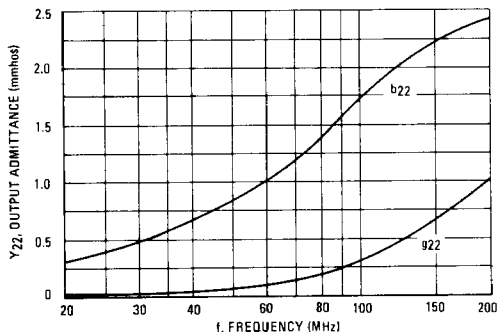


FIGURE 15 — SINGLE-ENDED INPUT ADMITTANCE

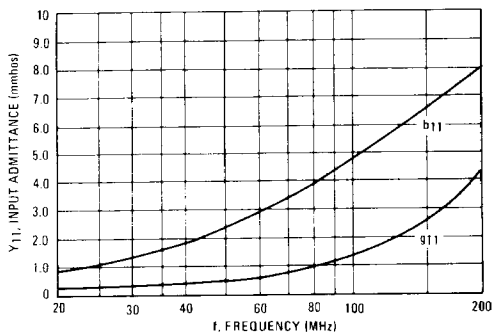


FIGURE 16 — HARMONIC DISTORTION versus AGC GAIN REDUCTION FOR AM CARRIER (For Test Circuit, See Figure 17)

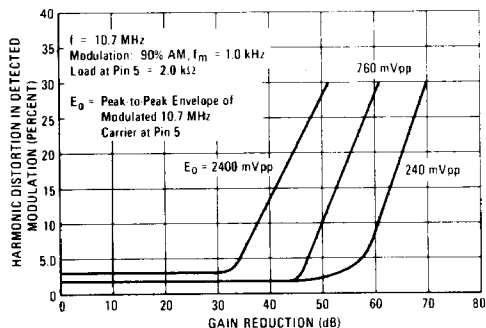


FIGURE 17 — 10.7 MHz AMPLIFIER

Gain = 55 dB, BW = 100 kHz

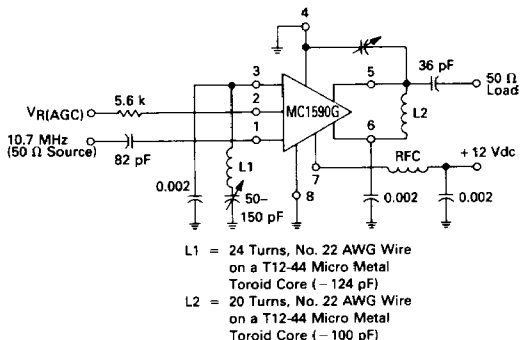


FIGURE 18 —  $Y_{21}$ , FORWARD TRANSFER ADMITTANCE RECTANGULAR FORM

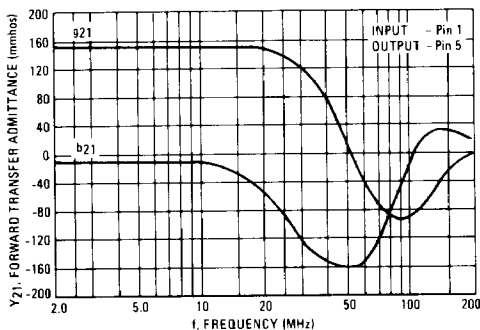
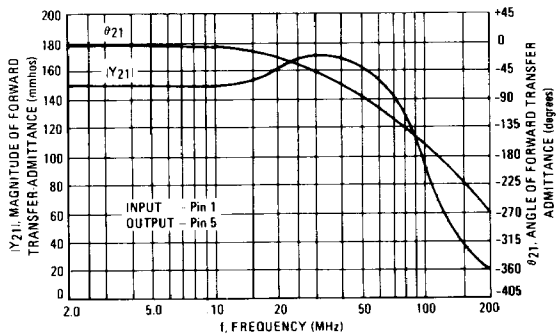


FIGURE 19 —  $Y_{21}$ , FORWARD TRANSFER ADMITTANCE POLAR FORM



TYPICAL CHARACTERISTICS (continued)

FIGURE 20 –  $S_{11}$  AND  $S_{22}$ , INPUT AND OUTPUT REFLECTION COEFFICIENT

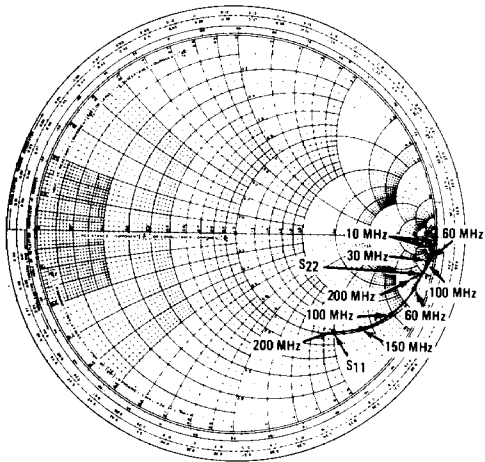


FIGURE 21 –  $S_{11}$  AND  $S_{22}$ , INPUT AND OUTPUT REFLECTION COEFFICIENT

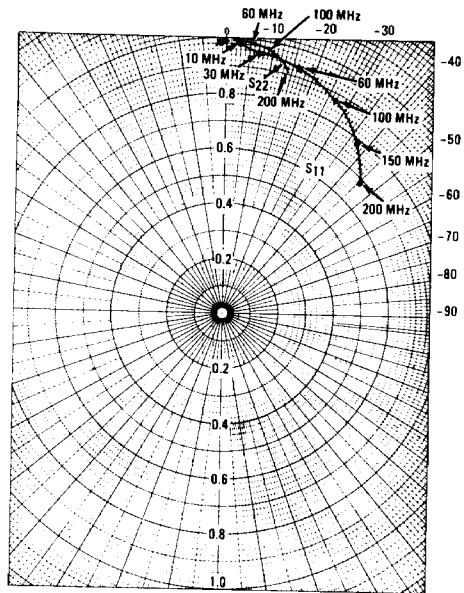


FIGURE 22 –  $S_{21}$ , FORWARD TRANSMISSION COEFFICIENT (GAIN)

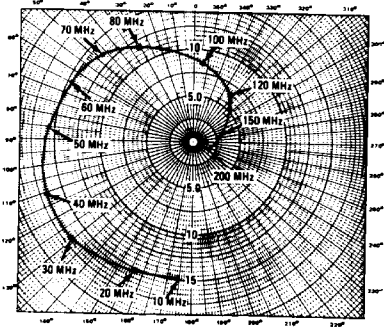
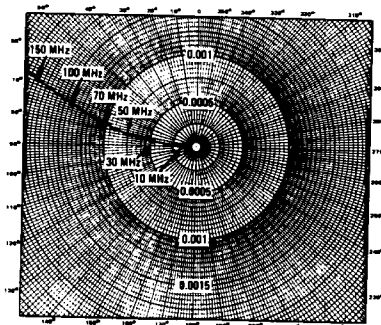


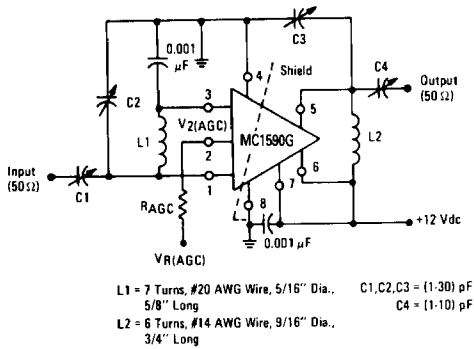
FIGURE 23 –  $S_{12}$ , REVERSE TRANSMISSION COEFFICIENT (FEEDBACK)



# MC1590G

## TYPICAL APPLICATIONS

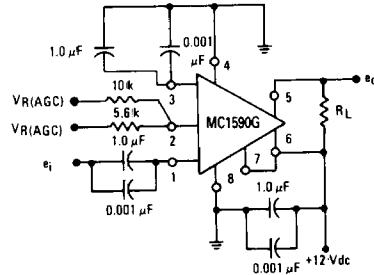
**FIGURE 24 — 60 MHz POWER GAIN TEST CIRCUIT**



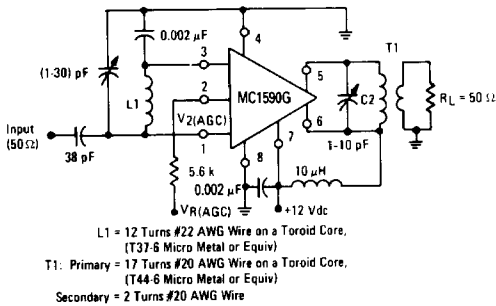
**FIGURE 25 — PROCEDURE FOR SETUP USING FIGURE 24**

Test	$e_{in}$	$V_2(AGC)$	$R_{AGC}(k\Omega)$
MAGC	2.23 mV (-40dBm)	5.7 V	0
Gp	1.0 mV (-47dBm)	$\leq 5.0$ V	5.6
NF	1.0 mV (-47dBm)	$\leq 5.0$ V	5.6

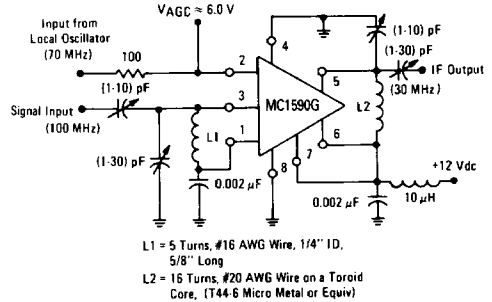
**FIGURE 26 — VIDEO AMPLIFIER**



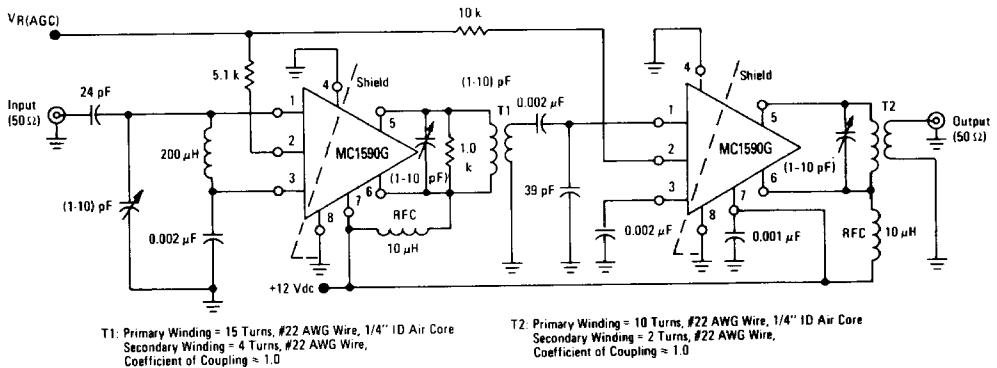
**FIGURE 27 — 30 MHz AMPLIFIER  
(Power Gain = 50 dB, BW = 1.0 MHz)**



**FIGURE 28 — 100 MHz MIXER**

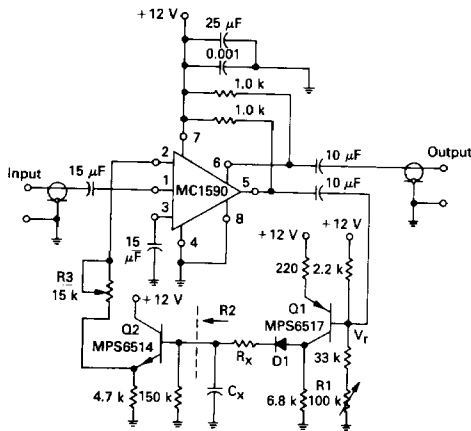


**FIGURE 29 — TWO-STAGE 60 MHz IF AMPLIFIER (Power Gain  $\approx 80$  dB, BW  $\approx 1.5$  MHz)**



## TYPICAL APPLICATIONS (continued)

FIGURE 30 – SPEECH COMPRESSOR



## DESCRIPTION OF SPEECH COMPRESSOR

The amplifier drives the base of a PNP MPS6517 operating common-emitter with a voltage gain of approximately 20. The control R1 varies the quiescent Q point of this transistor so that varying amounts of signal exceed the level  $V_r$ . Diode D1 rectifies the positive peaks of Q1's output only when these peaks are greater than  $V_r \approx 7.0$  Volts. The resulting output is filtered by  $C_x$ ,  $R_x$ .

$R_x$  controls the charging time constant or attack time.  $C_x$  is involved in both charge and discharge. R2 (the 150 kΩ and input resistance of the emitter-follower Q2) controls the decay time. Making the decay long and attack short is accomplished by making  $R_x$  small and R2 large. (A Darlington emitter-follower may be needed if extremely slow decay times are required.)

The emitter-follower Q2 drives the AGC Pin 2 of the MC1590G and reduces the gain. R3 controls the slope of signal compression. The following graph (Figure 31) details performance with R3 set to 15 kΩ.

FIGURE 31 – OUTPUT VOLTAGE versus INPUT VOLTAGE

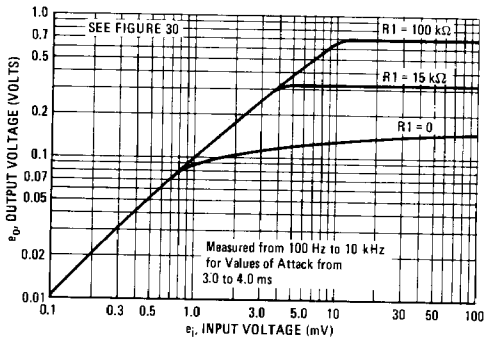


TABLE 1 — DISTORTION versus FREQUENCY

FREQUENCY	DISTORTION		DISTORTION	
	10 mV $e_i$	100 mV $e_i$	10 mV $e_i$	100 mV $e_i$
100 Hz	3.5%	12%	15%	27%
300 Hz	2%	10%	6%	20%
1.0 kHz	1.5%	8%	3%	9%
10 kHz	1.5%	8%	1%	3%
100 kHz	1.5%	8%	1%	3%

- Notes 1 and 2
- Notes 3 and 4
- Note: (1) Decay = 300 ms  
Attack = 20 ms
- (2)  $C_x = 7.5 \mu\text{F}$   
 $R_x = 0$  (Short)
- (3) Decay = 20 ms  
Attack = 3 ms
- (4)  $C_x = 0.68 \mu\text{F}$   
 $R_x = 1.5 k\Omega$

FIGURE 32 – OUTPUT CURRENT, CURRENT MATCH AND  $I_{CC}$  FIXTURE

