



## LOW POWER J-FET SINGLE OPERATIONAL AMPLIFIERS

- VERY LOW POWER CONSUMPTION :  
200 $\mu$ A
- WIDE COMMON-MODE (UP TO  $V_{CC}^+$ ) AND DIFFERENTIAL VOLTAGE RANGES
- LOW INPUT BIAS AND OFFSET CURRENTS
- OUTPUT SHORT-CIRCUIT PROTECTION
- HIGH INPUT IMPEDANCE J-FET INPUT STAGE
- INTERNAL FREQUENCY COMPENSATION
- LATCH UP FREE OPERATION
- HIGH SLEW RATE : 3.5V/ $\mu$ s

### DESCRIPTION

The TL061, TL061A and TL061B are high speed J-FET input single operational amplifiers family. Each of these J-FET input operational amplifiers incorporates well matched, high voltage J-FET and bipolar transistors in a monolithic integrated circuit.

The devices feature high slew rates, low input bias and offset currents, and low offset voltage temperature coefficient.

### PIN CONNECTIONS (top view)

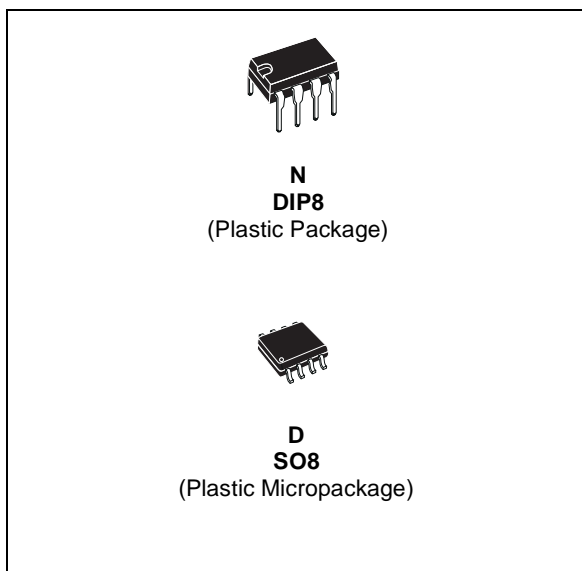
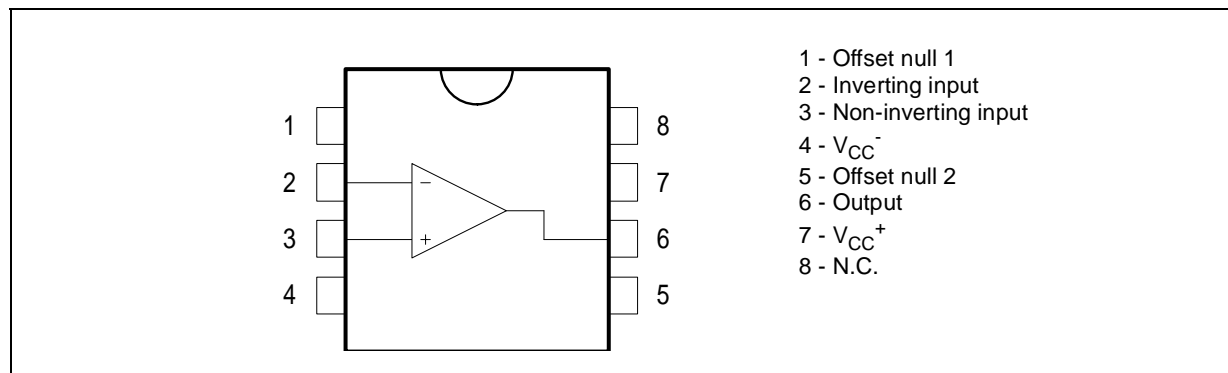

### ORDER CODE

Part Number	Temperature Range	Package	
		N	D
TL061M/AM/BM	-55°C, +125°C	•	•
TL061I/AI/BI	-40°C, +105°C	•	•
TL061C/AC/BC	0°C, +70°C	•	•
<b>Example : TL061IN</b>			

**N** = Dual in Line Package (DIP)  
**D** = Small Outline Package (SO) - also available in Tape & Reel (DT)

**SCHEMATIC DIAGRAM**

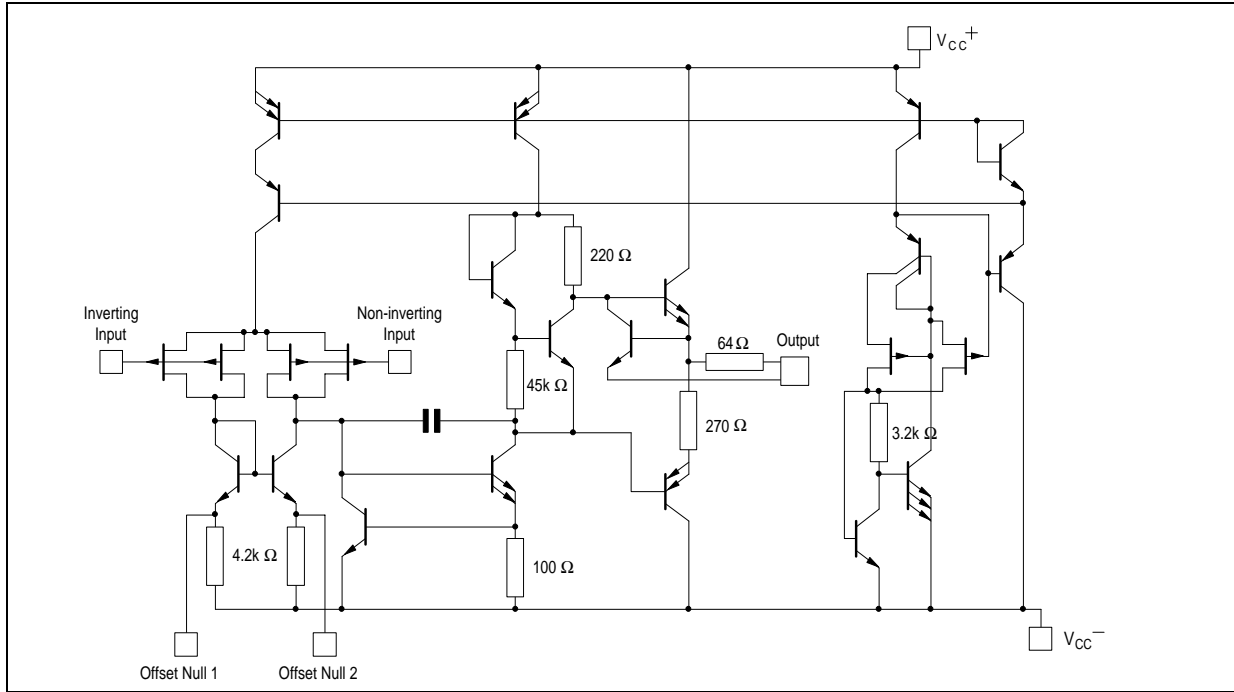

**INPUT OFFSET VOLTAGE NULL CIRCUIT**

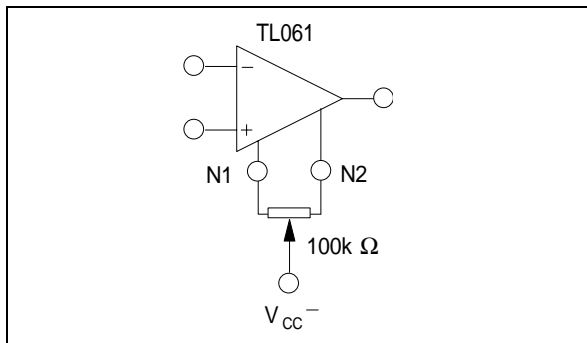

**ABSOLUTE MAXIMUM RATINGS**

Symbol	Parameter	TL061M, AM, BM	TL061I, AI, BI	TL061C, AC, BC	Unit
$V_{CC}$	Supply voltage - note <sup>1)</sup>	±18			V
$V_i$	Input Voltage - note <sup>2)</sup>	±15			V
$V_{id}$	Differential Input Voltage - note <sup>3)</sup>	±30			V
$P_{tot}$	Power Dissipation	680			mW
	Output Short-circuit Duration - note <sup>4)</sup>	Infinite			
$T_{oper}$	Operating Free-air Temperature Range	-55 to +125	-40 to +105	0 to +70	°C
$T_{stg}$	Storage Temperature Range	-65 to +150			°C

1. All voltage values, except differential voltage, are with respect to the zero reference level (ground) of the supply voltages where the zero reference level is the midpoint between  $V_{CC}^+$  and  $V_{CC}^-$ .
2. The magnitude of the input voltage must never exceed the magnitude of the supply voltage or 15 volts, whichever is less.
3. Differential voltages are the non-inverting input terminal with respect to the inverting input terminal.
4. The output may be shorted to ground or to either supply. Temperature and/or supply voltages must be limited to ensure that the dissipation rating is not exceeded.

**ELECTRICAL CHARACTERISTICS**

$V_{CC} = \pm 15V$ ,  $T_{amb} = +25^{\circ}C$  (unless otherwise specified)

Symbol	Parameter	TL061M			TL061I			TL061C			Unit
		Min.	Typ.	Max.	Min.	Typ.	Max.	Min.	Typ.	Max.	
$V_{io}$	Input Offset Voltage ( $R_S = 50\Omega$ ) $T_{amb} = +25^{\circ}C$ $T_{min} \leq T_{amb} \leq T_{max}$		3	6 9		3	6 9		3	15 20	mV
$DV_{io}$	Temperature Coefficient of Input Offset Voltage ( $R_S = 50\Omega$ )		10			10			10		$\mu V/^{\circ}C$
$I_{io}$	Input Offset Current- note <sup>1)</sup> $T_{amb} = +25^{\circ}C$ $T_{min} \leq T_{amb} \leq T_{max}$		5	100 20		5	100 10		5	200 5	$\mu A$ nA
$I_{ib}$	Input Bias Current -note 1 $T_{amb} = +25^{\circ}C$ $T_{min} \leq T_{amb} \leq T_{max}$		30	200 50		30	200 20		30	400 10	$\mu A$ nA
$V_{icm}$	Input Common Mode Voltage Range	$\pm 11.5$	+15 -12		$\pm 11.5$	+15 -12		$\pm 11$	+15 -12		V
$V_{opp}$	Output Voltage Swing ( $R_L = 10k\Omega$ ) $T_{amb} = +25^{\circ}C$ $T_{min} \leq T_{amb} \leq T_{max}$	20 20	27		20 20	27		20 20	27		V
$A_{vd}$	Large Signal Voltage Gain $R_L = 10k\Omega$ , $V_o = \pm 10V$ , $T_{amb} = +25^{\circ}C$ $T_{min} \leq T_{amb} \leq T_{max}$	4 4	6		4 4	6		3 3	6		V/mV
GBP	Gain Bandwidth Product $T_{amb} = +25^{\circ}C$ , $R_L = 10k\Omega$ , $C_L = 100pF$		1			1			1		MHz
$R_i$	Input Resistance		$10^{12}$			$10^{12}$			$10^{12}$		$\Omega$
CMR	Common Mode Rejection Ratio $R_S = 50\Omega$	80	86		80	86		70	76		dB
SVR	Supply Voltage Rejection Ratio $R_S = 50\Omega$	80	95		80	95		70	95		dB
$I_{CC}$	Supply Current, no load $T_{amb} = +25^{\circ}C$ , no load, no signal		200	250		200	250		200	250	$\mu A$
$P_D$	Total Power Consumption $T_{amb} = +25^{\circ}C$ , no load, no signal		6	7.5		6	7.5		6	7.5	mW
SR	Slew Rate $V_i = 10V$ , $R_L = 10k\Omega$ , $C_L = 100pF$ , $A_v = 1$	1.5	3.5		1.5	3.5		1.5	3.5		V/
$t_r$	Rise Time $V_i = 20mV$ , $R_L = 10k\Omega$ , $C_L = 100pF$ , $A_v = 1$		0.2			0.2			0.2		$\mu s$
$K_{ov}$	Overshoot Factor (see figure 1) $V_i = 20mV$ , $R_L = 10k\Omega$ , $C_L = 100pF$ , $A_v = 1$		10			10			10		%
$e_n$	Equivalent Input Noise Voltage $R_S = 100\Omega$ , $f = 1KHz$		42			42			42		$\frac{nV}{\sqrt{Hz}}$

1. The input bias currents of a FET-input operational amplifier are normal junction reverse currents, which are temperature sensitive. Pulse techniques must be used that will maintain the junction temperature as close to the ambient temperature as possible.

**ELECTRICAL CHARACTERISTICS**

$V_{CC} = \pm 15V$ ,  $T_{amb} = +25^{\circ}C$  (unless otherwise specified)

Symbol	Parameter	TL061AC, AI, AM			TL061BC, BI, BM			Unit
		Min.	Typ.	Max.	Min.	Typ.	Max.	
$V_{io}$	Input Offset Voltage ( $R_S = 50\Omega$ ) $T_{amb} = +25^{\circ}C$ $T_{min} \leq T_{amb} \leq T_{max}$		3	6 7.5		2	3 5	mV
$DV_{io}$	Temperature Coefficient of Input Offset Voltage ( $R_S = 50\Omega$ )		10			10		$\mu V/^{\circ}C$
$I_{io}$	Input Offset Current - note 1) $T_{amb} = +25^{\circ}C$ $T_{min} \leq T_{amb} \leq T_{max}$		5	100 3		5	100 3	pA nA
$I_{ib}$	Input Bias Current -note 1 $T_{amb} = +25^{\circ}C$ $T_{min} \leq T_{amb} \leq T_{max}$		30	200 7		30	200 7	pA nA
$V_{icm}$	Input Common Mode Voltage Range	$\pm 11.5$	+15 -12		$\pm 11$	+15 -12		V
$V_{opp}$	Output Voltage Swing ( $R_L = 10k\Omega$ ) $T_{amb} = +25^{\circ}C$ $T_{min} \leq T_{amb} \leq T_{max}$	20 20	27		20 20	27		V
$A_{vd}$	Large Signal Voltage Gain $R_L = 10k\Omega$ , $V_o = \pm 10V$ , $T_{amb} = +25^{\circ}C$ $T_{min} \leq T_{amb} \leq T_{max}$	4 4	6		4 4	6		V/mV
GBP	Gain Bandwidth Product $T_{amb} = +25^{\circ}C$ , $R_L = 10k\Omega$ , $C_L = 100pF$		1			1		MHz
$R_i$	Input Resistance		$10^{12}$			$10^{12}$		$\Omega$
CMR	Common Mode Rejection Ratio $R_S = 50\Omega$	80	86		80	86		dB
SVR	Supply Voltage Rejection Ratio $R_S = 50\Omega$	80	95		80	95		dB
$I_{CC}$	Supply Current, no load $T_{amb} = +25^{\circ}C$ , no load, no signal		200	250		200	250	$\mu A$
$P_D$	Total Power Consumption $T_{amb} = +25^{\circ}C$ , no load, no signal		6	7.5		6	7.5	mW
SR	Slew Rate $V_i = 10V$ , $R_L = 10k\Omega$ , $C_L = 100pF$ , $A_v = 1$	1.5	3.5		1.5	3.5		V/ $\mu s$
$t_r$	Rise Time $V_i = 20mV$ , $R_L = 10k\Omega$ , $C_L = 100pF$ , $A_v = 1$		0.2			0.2		$\mu s$
$K_{ov}$	Overshoot Factor (see figure 1) $V_i = 20mV$ , $R_L = 10k\Omega$ , $C_L = 100pF$ , $A_v = 1$		10			10		%
$e_n$	Equivalent Input Noise Voltage $R_S = 100\Omega$ , $f = 1KHz$		42			42		$\frac{nV}{\sqrt{Hz}}$

1. The input bias currents of a FET-input operational amplifier are normal junction reverse currents, which are temperature sensitive. Pulse techniques must be used that will maintain the junction temperature as close to the ambient temperature as possible.

**MAXIMUM PEAK-TO-PEAK OUTPUT VOLTAGE versus SUPPLY VOLTAGE**

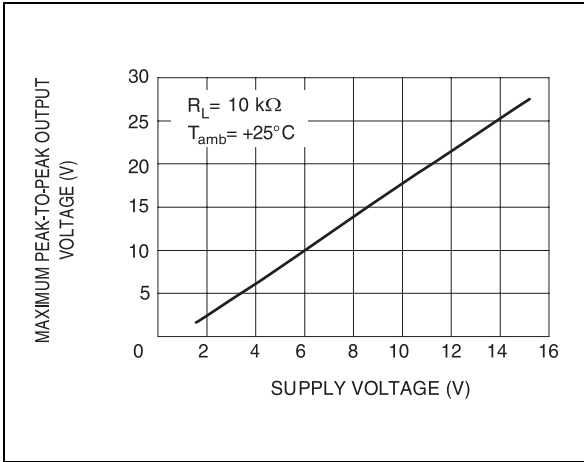

**MAXIMUM PEAK-TO-PEAK OUTPUT VOLTAGE versus FREE AIR TEMPERATURE**

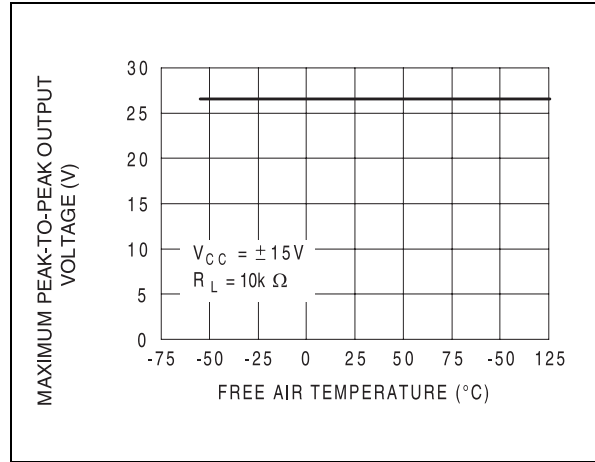

**MAXIMUM PEAK-TO-PEAK OUTPUT VOLTAGE versus LOAD RESISTANCE**

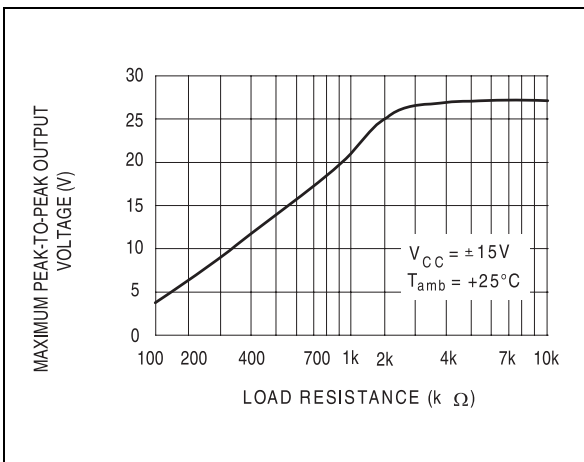

**MAXIMUM PEAK-TO-PEAK OUTPUT VOLTAGE versus FREQUENCY**

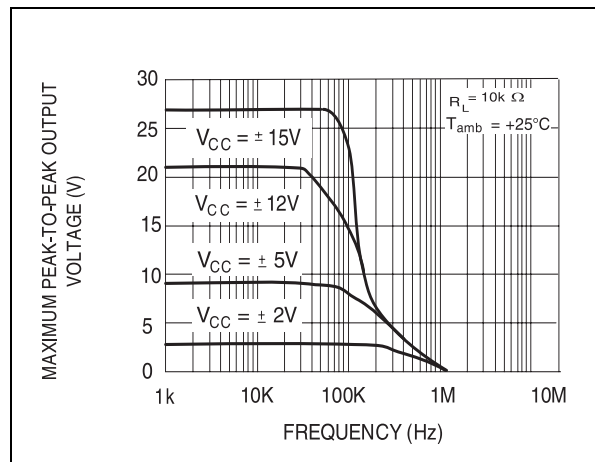

**DIFFERENTIAL VOLTAGE AMPLIFICATION versus FREE AIR TEMPERATURE**

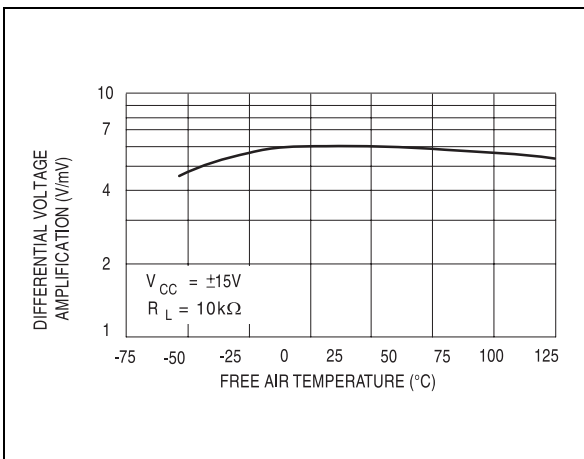

**LARGE SIGNAL DIFFERENTIAL VOLTAGE AMPLIFICATION AND PHASE SHIFT versus FREQUENCY**

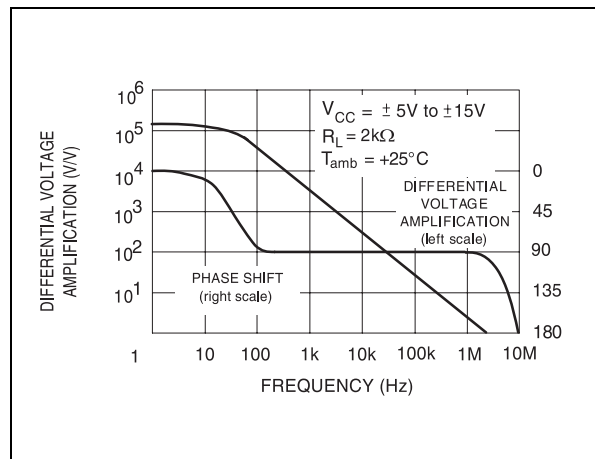

**SUPPLY CURRENT PER AMPLIFIER versus SUPPLY VOLTAGE**

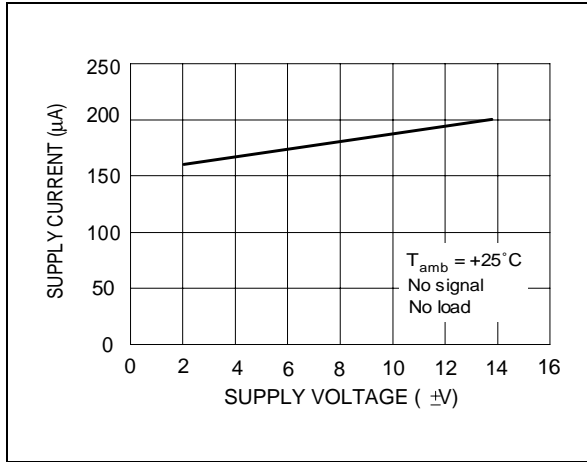

**SUPPLY CURRENT PER AMPLIFIER versus FREE AIR TEMPERATURE**

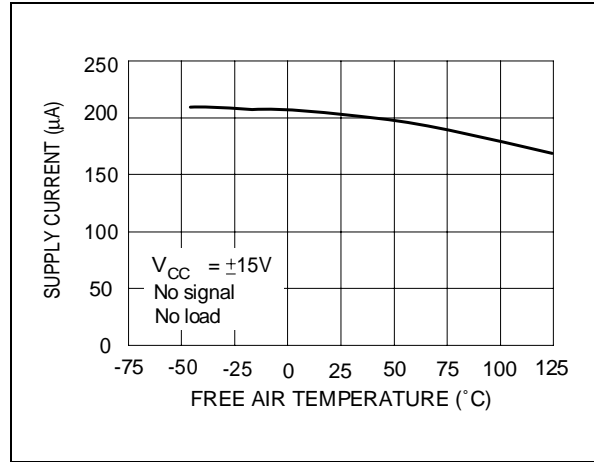

**TOTAL POWER DISSIPATED versus FREE AIR TEMPERATURE**

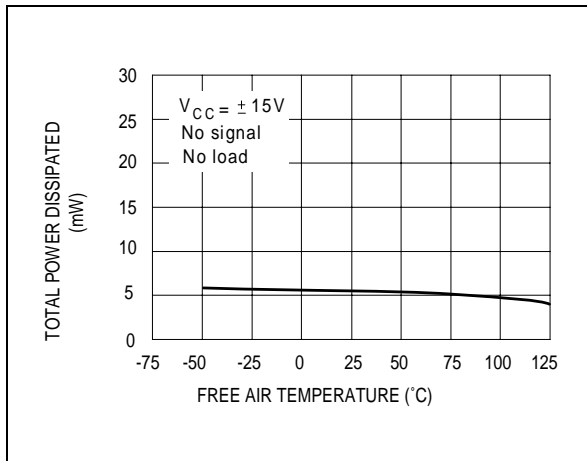

**COMMON MODE REJECTION RATIO versus FREE AIR TEMPERATURE**

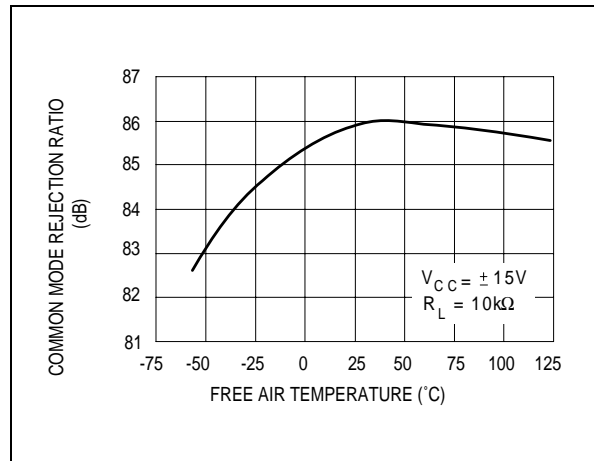

**NORMALIZED UNITY GAIN BANDWIDTH, SLEW RATE, AND PHASE SHIFT versus TEMPERATURE**

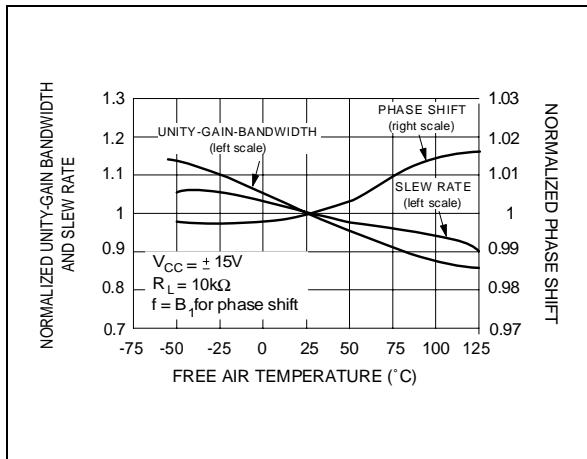

**INPUT BIAS CURRENT versus FREE AIR TEMPERATURE**

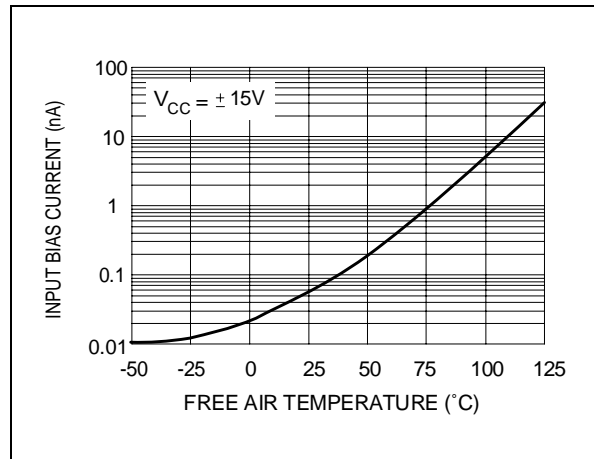

**VOLTAGE FOLLOWER LARGE SIGNAL PULSE RESPONSE**

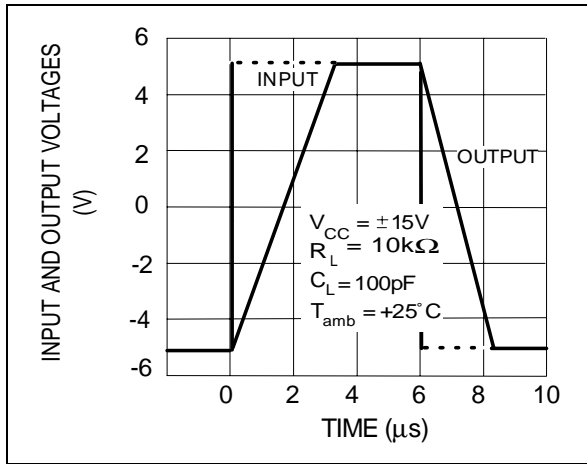

**OUTPUT VOLTAGE versus ELAPSED TIME**

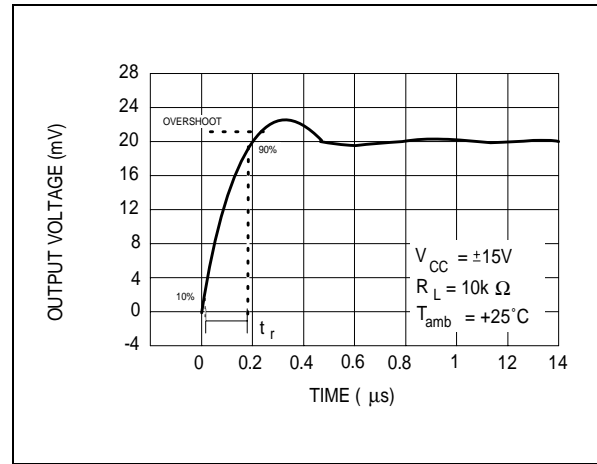

**EQUIVALENT INPUT NOISE VOLTAGE versus FREQUENCY**

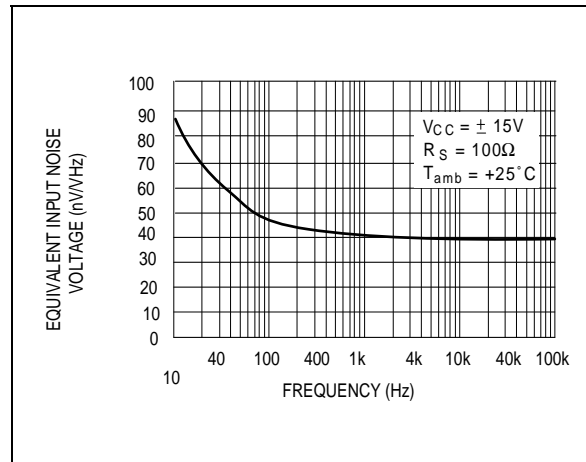

**PARAMETER MEASUREMENT INFORMATION**

**Figure 1 : Voltage Follower**

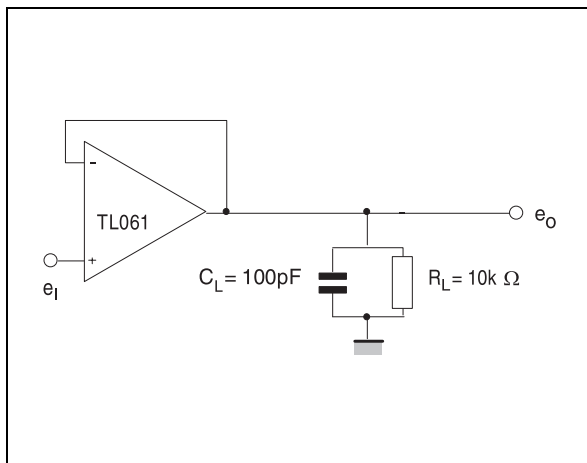

**Figure 2 : Gain-of-10 inverting amplifier**

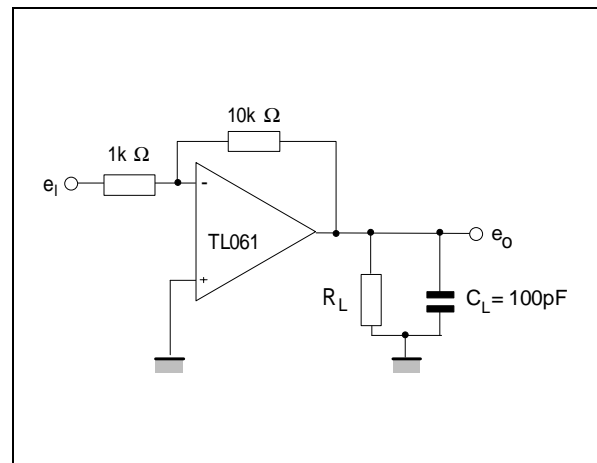

**PACKAGE MECHANICAL DATA**  
8 PINS - PLASTIC DIP

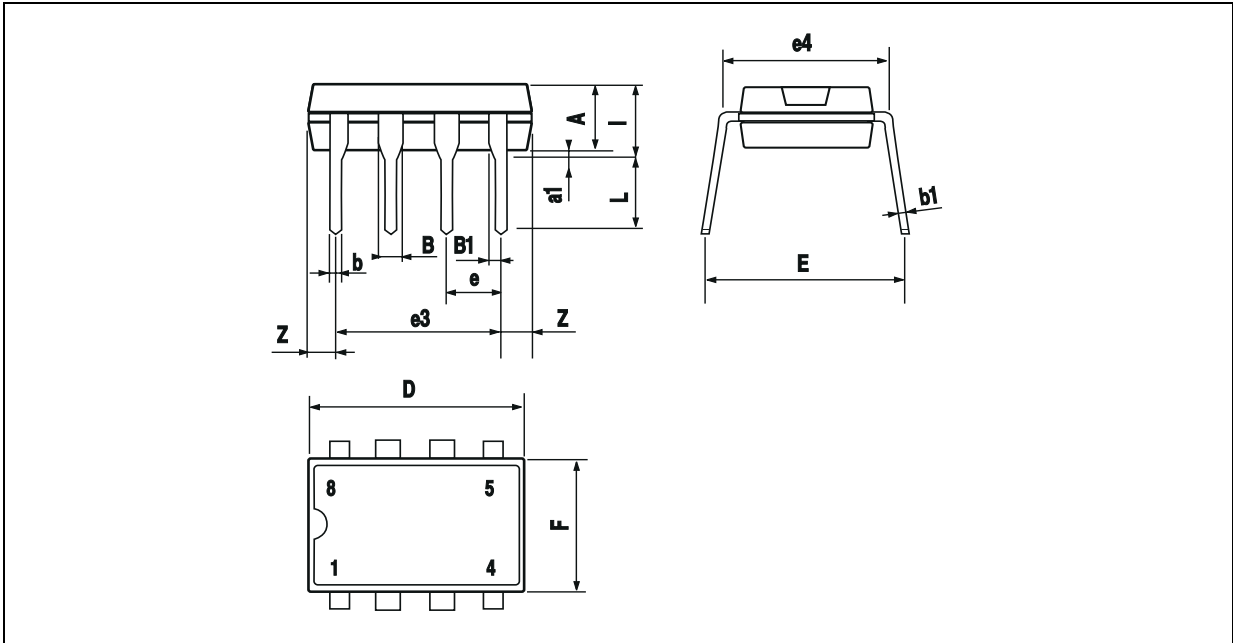

Dimensions	Millimeters			Inches		
	Min.	Typ.	Max.	Min.	Typ.	Max.
A		3.32			0.131	
a1	0.51			0.020		
B	1.15		1.65	0.045		0.065
b	0.356		0.55	0.014		0.022
b1	0.204		0.304	0.008		0.012
D			10.92			0.430
E	7.95		9.75	0.313		0.384
e		2.54			0.100	
e3		7.62			0.300	
e4		7.62			0.300	
F			6.6			0.260
i			5.08			0.200
L	3.18		3.81	0.125		0.150
Z			1.52			0.060

**PACKAGE MECHANICAL DATA**  
8 PINS - PLASTIC MICROPACKAGE (SO)

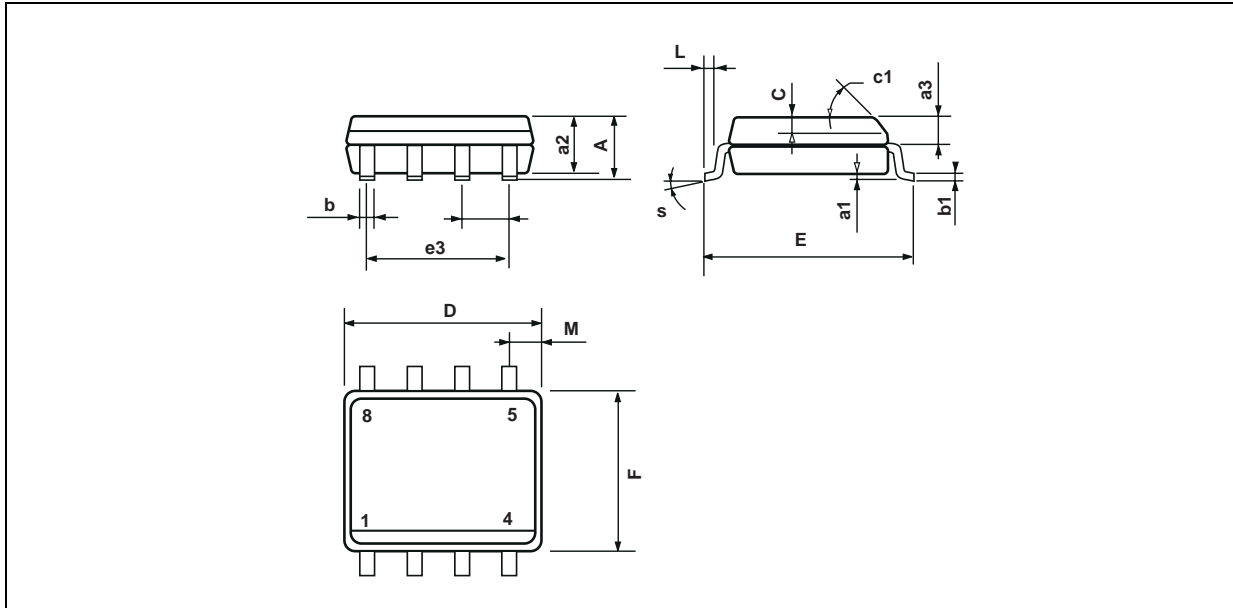

Dimensions	Millimeters			Inches		
	Min.	Typ.	Max.	Min.	Typ.	Max.
A			1.75			0.069
a1	0.1		0.25	0.004		0.010
a2			1.65			0.065
a3	0.65		0.85	0.026		0.033
b	0.35		0.48	0.014		0.019
b1	0.19		0.25	0.007		0.010
C	0.25		0.5	0.010		0.020
c1	45° (typ.)					
D	4.8		5.0	0.189		0.197
E	5.8		6.2	0.228		0.244
e		1.27			0.050	
e3		3.81			0.150	
F	3.8		4.0	0.150		0.157
L	0.4		1.27	0.016		0.050
M			0.6			0.024
S	8° (max.)					

Information furnished is believed to be accurate and reliable. However, STMicroelectronics assumes no responsibility for the consequences of use of such information nor for any infringement of patents or other rights of third parties which may result from its use. No license is granted by implication or otherwise under any patent or patent rights of STMicroelectronics. Specifications mentioned in this publication are subject to change without notice. This publication supersedes and replaces all information previously supplied. STMicroelectronics products are not authorized for use as critical components in life support devices or systems without express written approval of STMicroelectronics.

© The ST logo is a registered trademark of STMicroelectronics

© 2001 STMicroelectronics - Printed in Italy - All Rights Reserved  
STMicroelectronics GROUP OF COMPANIES

Australia - Brazil - China - Finland - France - Germany - Hong Kong - India - Italy - Japan - Malaysia - Malta - Morocco  
Singapore - Spain - Sweden - Switzerland - United Kingdom

© <http://www.st.com>



This datasheet has been download from:

[www.datasheetcatalog.com](http://www.datasheetcatalog.com)

Datasheets for electronics components.